

28-2-95
\$

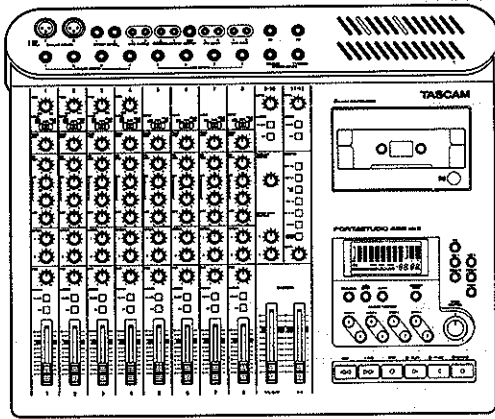

TASCAM

TEAC Professional Division

SERVICE MANUAL

488MKII

PORTASTUDIO

NOTES

As regards the resistors and capacitors, refer to the circuit diagrams and the PCB ass'y drawings contained in this manual.

- PC boards shown viewed from parts side.
- Parts marked with * require longer deliver time.
- Δ Parts marked with this sign are safety critical components. They must always be replaced with identical components — refer to the TEAC Parts List and ensure exact replacement.
- Parts not shown in the parts lists, or parts, though listed, having no parts numbers, are not general "ready-to-supply" parts.
- Parts of [] mark can be used only with the version designated.
[J]: JAPAN [US/C]: U.S.A./CANADA [E]: EUROPE
[UK]: U.K. [A]: AUSTRALIA

注意

標準抵抗、コンデンサーは省略してあります。回路図および基板図を参照してください。

- プリント基板図は部品面が示されています。
- *印の部品は納期が若干かかります。あらかじめご了承ください。
- Δ 印は安全規格重要部品です。交換するときは必ずティアック指定の部品を使用してください。
- リストされていない部品は原則としてサービス供給部品として取扱っていません。
- 仕向け先
[J]: JAPAN [US/C]: U.S.A./CANADA [E]: EUROPE
[UK]: U.K. [A]: AUSTRALIA

INSTRUCTIONS FOR SERVICE PERSONNEL

BEFORE RETURNING APPLIANCE TO THE CUSTOMER, MAKE LEAKAGE - CURRENT OR RESISTANCE MEASUREMENTS TO DETERMINE THAT EXPOSED PARTS ARE ACCEPTABLY INSULATED FROM THE SUPPLY CIRCUIT.

1. SPECIFICATIONS

仕様

Mechanical Characteristics

Tape:	Compact Cassette (C-30 to 90), High-Bias (Type II, CrO ₂)
Track Format:	8-track/8-channel, single directional record/play
Head Configuration:	8-channel record/play (hard permalloy) x 1 8-channel erase (ferrite) x 1
Motor:	DC servo capstan motor x 1 DC reel motor x 1 DC ancillary motor x 1
Tape Speed:	9.5 cm/sec. (3-3/4 ips), ± 1%
Pitch Control:	± 12 % (approx.)
Wow and Flutter:	0.04% WRMS, ± 0.06 % W.Peak
Fast Winding Time:	80 sec. (approx.) with C-60
Dimension (W × H × D)	528.4 × 128 × 437 mm (20-13/16" × 5-1/16" × 17-3/16")
Weight:	7.1 kg (15-10/16 lbs.)

Electrical Characteristics**Mixer Section****MIC/LINE INPUTS [CH1, CH2]**
(XLR type connector x 2)**Input Impedance:**

2.8k ohms

Nominal Input Level:

-60 dBV (1mV) (MIC position)

-20 dBV (0.1 V) (LINE position)

+5 dBV (1.8 V) at Trim Min.

Maximum Input Level:**MIC/LINE INPUTS [CH1, CH2]**

(1/4" phone jack x 2)

Input Impedance:

5.8k ohms

Nominal Input Level:

-50 dBV (3mV) (MIC position)

-10 dBV (0.3 V) (LINE position)

+5 dBV (1.8 V) at Trim Min.

Maximum Input Level:**MIC/LINE INPUTS [CH3, CH4]**

(1/4" phone jack x 2)

Input Impedance:

50k ohms

Nominal Input Level:

-50 dBV (3 mV) (MIC position)

-10 dBV (0.3 V) (LINE position)

+5 dBV (1.8 V) at Trim Min.

Maximum Input Level:**LINE INPUTS [CH5 — CH8]**

(1/4" phone jack x 4)

Input Impedance:

50k ohms

Nominal Input Level:

-10 dBV (0.3 V)

Maximum Input Level:

+5 dBV (1.8 V)

STEREO INPUTS [CH9 — CH12]

(1/4" phone jack x 4)

Input Impedance:

10k ohms

Nominal Input Level:

-10 dBV (0.3 V)

Maximum Input Level:

+5 dBV (1.8 V)

INSERT [CH1, CH2]**Input Impedance:**

10k ohms

Nominal Input Level:

-10 dBV (0.3 V)

Maximum Input Level:

+5 dBV (1.8 V)

Output Impedance:

10k ohms

Minimum Load Impedance:

2k ohms

Nominal Output Level:

-10 dBV (0.3 V)

2TR INPUT (RCA jack x 2)	
Input Impedance:	47k ohms
Nominal Input Level:	-10 dBV (0.3 V)
Maximum Input Level:	+5 dBV (1.8 V)
SUB INPUT (RCA jack x 2)	
Input Impedance:	47k ohms
Nominal Input Level:	-10 dBV (0.3 V)
Maximum Input Level:	+5 dBV (1.8 V)
LINE OUTPUT (RCA jack x 2)	
Output Impedance:	100 ohms
Minimum Load Impedance:	2k ohms
Nominal Output Level:	-10 dBV (0.3 V)
EFFECT SENDS [1, 2] (RCA jack x 2)	
Output Impedance:	100 ohms
Minimum Load Impedance:	2k ohms
Nominal Output Level:	-10 dBV (0.3 V)
MONITOR OUTPUT (RCA jack x 2)	
Output Impedance:	100 ohms
Minimum Load Impedance:	2k ohms
Nominal Output Level:	-10 dBV (0.3 V)
CUE OUTPUT (RCA jack x 1)	
Output Impedance:	100 ohms
Minimum Load Impedance:	2k ohms
Nominal Output Level:	-10 dBV (0.3 V)
SYNC IN (RCA jack x 1)	
Input Impedance:	10k ohms
Nominal Input Level:	-10 dBV (0.3 V)
SYNC OUT (RCA jack x 1)	
Output Impedance:	100 ohms
Minimum Load Impedance:	2k ohms
Nominal Output Level:	-10 dBV (0.3 V)
PHONES (1/4" stereo phone jack x 1)	
Nominal Load Impedance:	30 ohms
Maximum Output Level:	100 mW (approx.)
Equalizer	
HIGH (Shelving):	10 kHz, ± 12 dB
MID (Parametric):	250 Hz to 5 kHz, ± 12 dB
LOW (Shelving):	100 Hz, ± 12 dB
Frequency Response:	20 Hz to 22 kHz, ± 1 -2 dB
Signal-to-Noise Ratio	
(at Nominal Input/Output Level):	UNWTD(20 Hz to 20 kHz)/IHF A WTD
1 MIC INPUT — LINE OUTPUT	65 dB / 68 dB
4 MIC INPUTS — LINE OUTPUT	60 dB / 63 dB
1 LINE INPUT — LINE OUTPUT	79 dB / 83 dB
8 LINE INPUT — LINE OUTPUT	76 dB / 79 dB
Distortion	
1 MIC INPUT — LINE OUTPUT	0.05% (at 1 kHz, 20 dB above nominal input level with 30 kHz low-pass filter inserted)
1 LINE INPUT — LINE OUTPUT	0.05% (at 1 kHz, nominal input level)
Crosstalk:	
	55 dB (at 1 kHz, nominal input level with 30 kHz low-pass filter inserted)

Recorder Section

Frequency Response (overall):
Signal-to-Noise Ratio (overall):

40 Hz to 14 kHz, ± 3 dB (without dbx)
 UNWTD (20 Hz to 20 kHz)/IHF A WTD (at 3% distortion)
 54 dB/58 dB (without dbx)
 90 dB/95 dB (with dbx)
 1.3% (at 400 Hz, 0 dB level)

Total Harmonic Distortion:
Crosstalk (Channel Separation):

50 dB (without dbx, at 1 kHz, 0 dB level)
 70 dB (with dbx, at 1 kHz, 0 dB level)
 65 dB (at 1 kHz, +10 dB level)

Erasure:

Others

Power Requirements

USA/CANADA:

120 V AC, 60 Hz

EUROPE:

230 V AC, 50 Hz

U.K./AUSTRALIA:

240 V AC, 50 Hz

JAPAN

100 V AC, 50/60 Hz

Power Consumption:

39 W

In these specifications, 0 dBV is referenced to 1 Volt. Actual voltage levels are also given in parenthesis (0.316 V for -10 dBV rounded off to 0.3 V).

* dbx is a registered trademark of dbx Incorporated.

■ Changes in specifications and features may be made without notice or obligation.

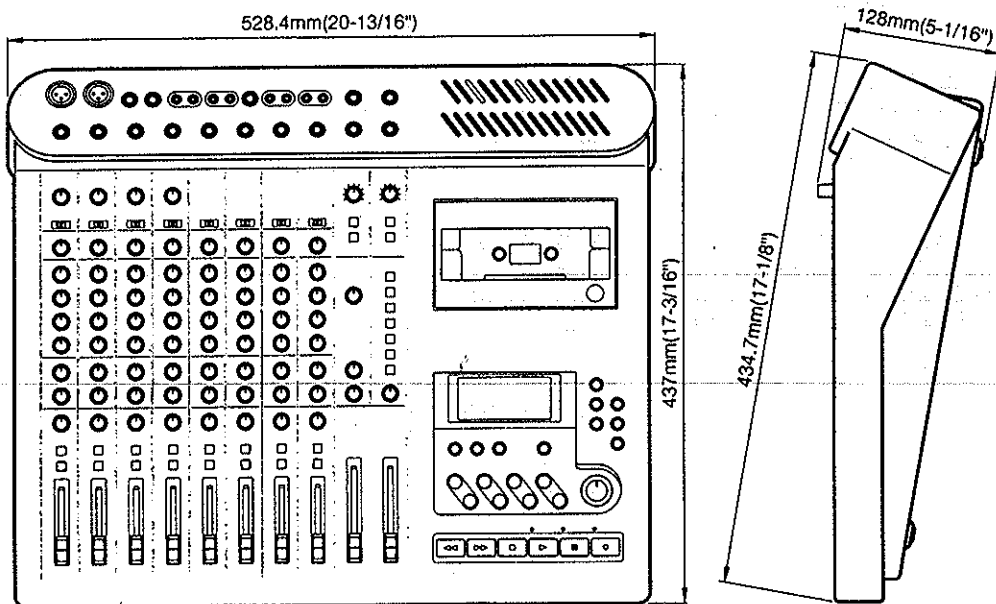

2. MECHANICAL CHECKS AND ADJUSTMENTS

機構部の確認と調整

2-1. Test tape/equipment

1. Cassette Torque Meter

For checking takeup and supply torque

Sansei Riko model SRK-CT-W100 or

TEAC MTT-8902

• Sansei Riko model SRK-CT-W100

T.T.: 0 ~ 120 g·cm

B.T.: 0 ~ 14 g·cm

• TEAC MTT-8902

T.T.: 0 ~ 130 g·cm

B.T.: 10 ~ 17 g·cm

For checking fast winding torque

Sony model TW-2231 or TEAC MTT-8242

• Sony model TW-2231

0 ~ 200 g·cm

• TEAC MTT-8242

0 ~ 250 g·cm

2. Mirror Tape

• TEAC model MTT-902

For checking tape positioning

C-90 type

3. Test Tape

• TEAC model MXT-111

For checking tape speed and wow/flutter (reproduce method)

Signal level: 3000 Hz/0 dB

• TEAC model MTT-5562

For checking Wow/flutter (record/repro method)

Chrome type, blank tape

• TEAC model MXT-1161

For checking azimuth and head-tape contact

2-2. Pinch Roller Pressure

1. Hold the STOP and REHEARSAL keys simultaneously, then turn the POWER on to activate the CLEANING mode (The Cleaning logo appears in the display).
2. Attach spring scale to the pinch arm.
3. Pull the scale in the direction indicated in Fig. 2-1 until the pinch roller fully separates from the capstan shaft, then slowly ease the scale so the pinch roller moves back toward the capstan shaft.
4. Note the reading on the spring scale the moment the pinch roller again starts rotating. The spring scale should indicate 380 ~ 500 g.
5. Press the STOP and COUNTER RESET keys simultaneously to exit the Cleaning mode.

2-1. テスト・テープ

1. カセット・トルク・メータ

テイク・アップ、サプライ・トルク チェック用

サンセイ理工製 SRK-CT-W100 又は TEAC MTT-8902

• サンセイ理工製 SRK-CT-W100

T.T.: 0 ~ 120 g·cm

B.T.: 0 ~ 14 g·cm

• TEAC MTT-8902

T.T.: 0 ~ 130 g·cm

B.T.: 10 ~ 17 g·cm

F.FWD, REWトルク チェック用

ソニー製 TW-2231 又は TEAC MTT-8242

• ソニー製 TW-2231

0 ~ 200 g·cm

• TEAC MTT-8242

0 ~ 250 g·cm

2. ミラー・テープ

• TEAC MTT-902

テープ・パス チェック用

C-90 タイプ

3. テスト・テープ

• TEAC MXT-111

テープ・スピード チェック用

ワウ・フラッタ (再生法) チェック用

信号レベル: 3000Hz/0dB

• TEAC MTT-5562

ワウ・フラッタ (録再法) チェック用

クロム・タイプ、ブランク・テープ

• TEAC MXT-1161

アジマス、ヘッド・タッチ チェック用

2-2. ピンチ・ローラ圧着力

1. STOPキーとREHEARSALキーを同時に押しながらPOWERスイッチをONにし、クリーニング・モードにする。Cleaningのロゴがディスプレイに表示される。
2. ピンチ・アームにバネ秤を掛ける。
3. ピンチ・ローラがキャプスタン・シャフトから完全に離れるように秤を矢印の方向 (Fig. 2-1) に引張った後、ピンチ・ローラが再びキャプスタン・シャフトに接触するように徐々に戻す。
4. ピンチ・ローラが回り始めるときの値を読む。
規格: 380 ~ 500 g
5. STOPキーとCOUNTER RESETキーを同時に押し、クリーニング・モードを解除する。

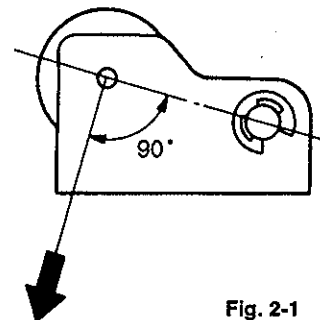

Fig. 2-1

2-3. Tape Positioning

CAUTION

After replacement of the rec/repro head as well as the erase head, gently tighten up screws A through G shown in Fig. 2-2, then loosen each of them by a 1.5 turn before attempting adjustments. Also, the following are required :

Head adjustment jig A (Part No. 5736006600)

Head adjustment jig B (Part No. 5736006700)

2-3. テープ走行

注意 : 録・再ヘッド及び消去ヘッドを交換したときにはFig. 2-2のネジ (A) ~ (G) を軽く締め切って、その位置からそれぞれのネジを1.5回転緩めた状態で調整を始めること。又、この調整を行うには次の治具が必要です。

ヘッド調整治具 A (P/N : 5736006600)

ヘッド調整治具 B (P/N : 5736006700)

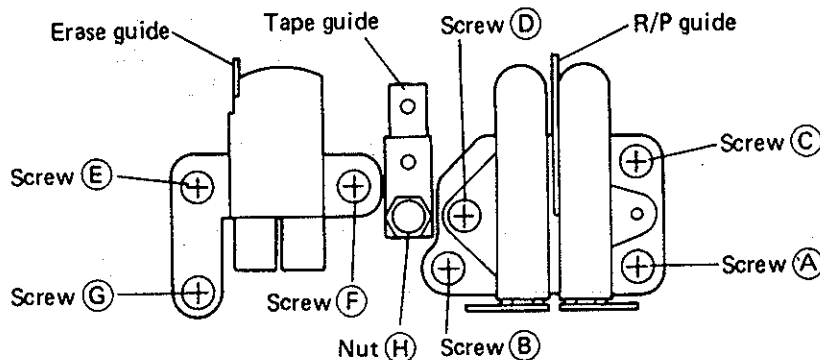

Fig. 2-2

1. Erase Head Height and Tilt

1. Set head adjustment jigs A and B as shown in Fig. 2-3, and enter play mode.
2. Hold the STOP and REHEARSAL keys simultaneously, then turn the POWER on to activate the CLEANING mode (The Cleaning logo appears in the display).
3. Adjust screw G until jig B touches the lower edge of the erase head tape guides.
4. Apply jig B to the head as shown in Fig. 2-4 to check head tilt. Adjustment is made by turning screws E and F by the same amount (within a 1/8 turn) until the head is perpendicular to the jig.
5. Recheck the head height.
6. Repeat steps 3 through 5 until the height and tilt are correct.

2. Tape Guide Height

7. Adjust nut H until jig B touches the tape guide upper edge.

1. 消去ヘッドの高さ及びチルト調整

- 1) ヘッド調整治具A、BをFig. 2-3のようにセットする。
- 2) STOPキーとREHEARSALキーを同時に押しながらPOWERスイッチをONにし、クリーニング・モードにする。Cleaningのロゴがディスプレイに表示される。
- 3) 治具Bが消去ヘッドのテープ・ガイドの下側に当たる様にネジGで高さを調整する。
- 4) Fig. 2-4の様に治具Bをヘッドに当てて、チルトを確認しヘッドが治具に対して垂直になる様に、ネジE、Fを同量(1/8回転以下)回し調整する。
- 5) 再度、ヘッドの高さを確認する。
- 6) 高さ及びチルトが最適になるまで3) ~ 5) 項を繰り返す。

2. テープ・ガイドの高さ調整

- 7) 治具Bがテープ・ガイドの上側に当たる様にナットHを回して調整する。

5. Tape Positioning

16. Run mirror tape TEAC MTT-902, and adjust screw C until the tape flushes with (and does not rub on) the lower edge of the rec/repro head tape guide. Check also the erase head and the tape are almost in parallel. If necessary, adjust screw F. When screw F is adjusted, be sure to recheck the head height and tilt.

6. Head-Tape Contact

17. Load test tape TEAC MXT-1161 and run it in play mode.
18. While the 10 kHz recording is playing back, repeatedly apply and release a slight finger pressure to the left reel and check that the level from CH 1 (connector pin 2 on DBX PCB) and CH 8 (connector pin 9 on DBX PCB) does not vary (tolerance: within 0.2 dB) as back tension varies.
19. If either channel level varies, adjust by giving the same amount of turn (within a 1/4 turn) to screws A and B (if the ch.1 level varies, loosen the screws; if the ch. 8 level varies, tighten the screws), then adjust screw C as stated in paragraph 5 above (Tape Positioning).
20. Recheck for any level variation. Repeat step 19 until there is no level variation.
21. If screws A and B were adjusted, be sure to go back to paragraph 4 above (Azimuth Adjustment) and repeat procedure starting from step 13.

7. Head Azimuth (Ch.5 - 8)

22. Play the 315 Hz, 2 kHz and the 6.3 kHz recording on test tape TEAC MXT-1161 and adjust screw D for phase matching between CH 5 (connector pin 6 on DBX PCB) and CH 8 (connector pin 9 on DBX PCB).

8. Tape Positioning

23. Run mirror tape TEAC MXT-902 in play and stop alternately to check that tape flushes with (and does not rub on) the following: tape guide lower edge of the erase and the rec/repro head, and the upper edge of the tape guide between the heads (Fig.2-6).

5. 走行調整

- 16) ミラー・テープ TEAC MTT-902を走行させ、録・再ヘッドのテープ・ガイド下側にテープが当たる様にネジCで調整する。又、消去ヘッドとテープがほぼ平行であることを確認し、傾いている場合にはネジFを回して調整する。ネジFを調整した場合は、高さ及びチルトを再調整する。

6. ヘッド・タッチ

- 17) テスト・テープ TEAC MXT-1161を装着し、プレイ・モードでテープを走行させる。
- 18) 10kHzを再生し、左リールを軽く手で押さえたり、離したりしてバック・テンションを変え1CH (DBX PCBのコネクタ2番ピン) 及び8CH (DBX PCBのコネクタ9番ピン) のレベルが変化しない (0.2dB以下) ことを確認する。
- 19) もし、どちらか一方のCHのレベルが変動するようであればネジA、Bを同量 (1/4回転以下) 回し (1CHがレベル変動する場合にはネジを締める様に、8CHがレベル変動する場合にはネジを緩める様に回す。) 5項 (走行調整) の要領でネジCを調整する。
- 20) 再度レベル変動を確認し、レベル変動が無くなるまで19) 項を繰り返す。
- 21) ネジA、Bを調整した場合には必ず、4項 (アジマス調整) に戻り、再度それ以後の項目を繰り返す。

7. ヘッド・アジマス (5CH - 8CH)

- 22) テスト・テープ TEAC MXT-1161の315Hz、2kHz、6.3kHzを再生したとき、5CH (DBX PCBのコネクタ6番ピン) と8CH (DBX PCBコネクタ9番ピン) の位相を合わせる様にネジDを回して調整する。

8. テープ走行確認

- 23) ミラー・テープ TEAC MXT-902を走行させ、Fig. 2-6の様にテープが消去ヘッド及び録・再ヘッドのテープ・ガイド下側、テープ・ガイド上側に当たり、かつテープのカールが無いことをストップ、プレイを繰り返し確認する。

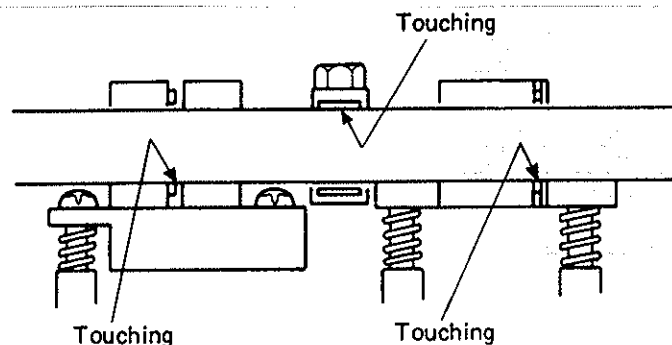

Fig. 2-6

2-4. Reel Torque

1. Takeup Torque/Back Tension

1. Set a cassette torque meter (SRK-CT-W100 or TEAC MTT-8902), enter play mode, and read the torque meter. If there is fluctuation in the reading, note the mean value. Specifications are as follows:

Takeup Torque (right reel side) : 20 - 65 g·cm

Back Tension (left reel side) : 11 - 15 g·cm

2. If back tension is out of specs, hold the STOP and CHECK keys simultaneously, then turn the POWER switch on to activate the ADJUST mode (The ADJ logo appears in the display). After setting the 488MKII in the ADJUST mode, turn the semi-fixed resistor R11 (Fig. 2-7) on CONTROL PCB until back tension is 12.5 g·cm. Press the STOP and CLEAR keys simultaneously to exit the ADJUST mode.

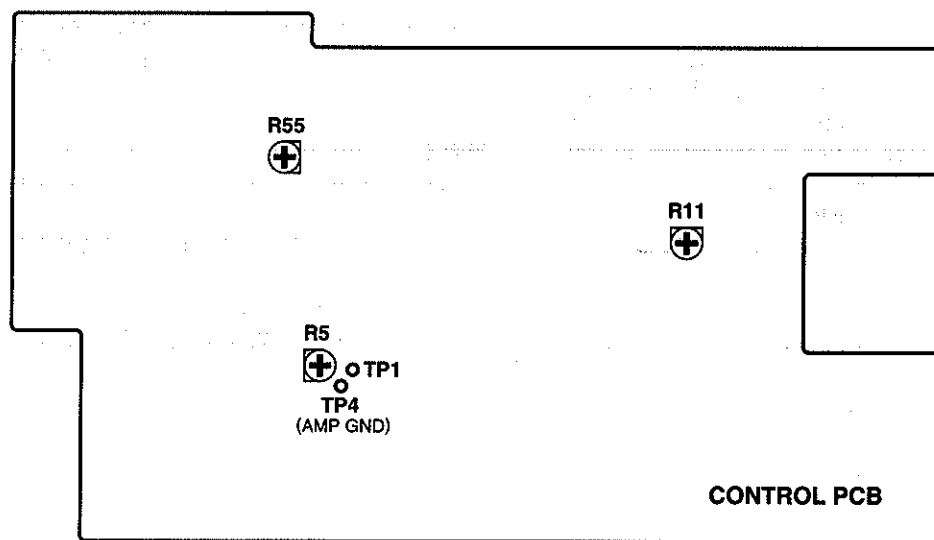

Fig. 2-7

2. Fast Winding Torque

Set a cassette torque meter (TW-2231 or TEAC MTT-8242) and check torque the instant F.F/REW is entered. Specifications are as follows:

F.F Torque (right reel side) : 70 - 180 g·cm

REW Torque (left reel side) : 70 - 180 g·cm

2-4. リール・トルク

1. テイク・アップ・トルク/バック・テンション

1) カセット・トルク・メータ (SRK-CT-W100、又は MTT-8902) を装着後、プレイ・モードにしトルク・メータの値を読む。振れのある場合は中心値とする。規定値は次の通りです。

テイク・アップ・トルク (右リール台) : 20 ~ 65g·cm

バック・テンション (左リール台) : 11 ~ 15g·cm

2) もしバック・テンションが上記値より外れている場合には、STOPキーとCHECKキーを同時に押しながらPOWERスイッチをONにし、アジャスト・モードにする。ADJのロゴがディスプレイに表示される。アジャスト・モード後、バック・テンションの値が12.5gになる様に、CONTROL PCBの半固定抵抗R11 (Fig. 2-7) を回して調整する。STOPキーとCLEARキーを同時に押し、アジャスト・モードを解除する。

2. F.F/REW トルク

カセット・トルク・メータ (TW-2231又はMTT-8242) を装着し、F.F動作及びREW動作の起動トルクをそれぞれ測定する。

規定値は次の通りです。

F.F.トルク (右リール台) : 70 ~ 180g·cm

REWトルク (左リール台) : 70 ~ 180g·cm

2-5. Tape Speed

1. Connect a frequency counter to CUE OUTPUT jack.
2. Set the PITCH CONTROL dial to its center position.
3. Turn POWER on.
4. Load test tape TEAC MXT-111 and play it for about 1 minute for warming up.
5. Play the middle section of the tape, and adjust adjustment resistor R55 (Fig. 2-7) on the CONTROL PCB assembly until the frequency reading is 3000 ± 5 Hz.
6. After adjustment, check for the following at both the beginning and the end of the tape:
 - Frequency reading: 3000 ± 45 Hz
 - Fluctuation: less than 30 Hz

2-6. Wow and Flutter

CAUTION:

Measurement should be repeated at the beginning, the middle, and the end of a test tape. (Wind the tape until tape pack on the right reel exceeds the first mark on the cassette half scale for taking measurement at the beginning of the tape; similarly, rewind the tape until tape pack on the left reel exceeds the first mark on the scale for measurement at the tape end.)

Reproduce Method

1. Connect a wow and flutter meter to the 488MK II as shown in Fig. 2-8.
2. Load a test tape TEAC MXT-111 or equivalent tapes and play it.
3. Note the reading on the wow/flutter meter. The reading should be 0.065% WRMS or less (weighted)

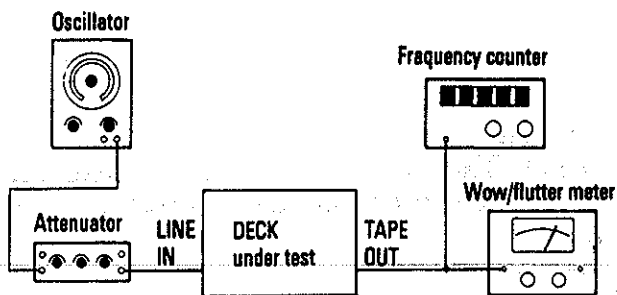

Fig. 2-8

2-5. テープ速度

1. 周波数カウンタをCUE OUTPUTに接続する。
2. ピッチ・コントロール・ダイヤルを中央にセットする。
3. POWERスイッチをONにする。
4. キャプスタン・モータを回転させウォーミング・アップする為にTEAC MXT-111を装着し、少なくとも1分間そのままにしておく。
5. テスト・テープの中間部を再生させて、テープ速度が $3,000 \pm 5$ Hzになる様にCONTROL PCB ASSYの半固定抵抗R55 (Fig. 2-7)を調整する。
6. 調整後、テープの巻き始めと巻き終りにて下記の値が得られるか確認する。
 - 速度偏差: $3,000 \pm 45$ Hz
 - 変動幅: 30Hz以下

2-6. ワウ・フラッタ

注意: 測定はテープの巻き始め、中間部、巻き終りでそれぞれ行って下さい。(但しハーフの巻き始めと巻き終わりの1目盛りを除く。)

再生法

1. Fig. 2-8の様にワウ・フラッタ・メータを488MK IIに接続する。
2. テスト・テープ TEAC MXT-111又は相当品を装着し再生する。
3. ワウ・フラッタ値を測定する。
 - 規格: 0.065% WRMS以下 (聴感補正值)

3. MIXER CHECKS

ミキサー部の信号チェック

Notes:

1. The nominal level at inputs and outputs is -10 dBV, 1 kHz.
2. Unless otherwise specified, turn each TRIM control to minimum level position (fully to LINE side) and set each EQ control to its center position.
3. Unless otherwise specified, control and fader setting once set should be left as they are for subsequent checking.
4. Unless otherwise specified, leave all switches in their OFF positions.

注意:

1. 各入出力に於ける基準レベル信号は、 1 kHz、 -10 dBVとする。
2. 特に指示が無い限り、各TRIMつまみは最小 (LINE側いっぱい)、各EQつまみはセンターの位置にセットしておくこと。
3. 特に指示が無い限り、一度セットしたつまみ、フェーダーはそれ以降のチェックのためそのままにしておくこと。
4. 特に指示が無い限り、スイッチ類はOFFにしておくこと。

3-1. MASTER 1/L-2/R Fader (Fig. 3-1)

1. Push the MASTER 1/L-2/R fader all the way up, apply a nominal level signal to SUB INPUT L and check for -2 ± 2 dBV at LINE OUT L.
2. Pull the MASTER 1/L-2/R fader until the level reading at LINE OUT L decreases by about 8 dB and is -10 dBV. When you did so, check to see that the MASTER 1/L-2/R fader is in the shaded area between 7 and 8 on the scale.
3. Apply a nominal level signal to SUB INPUT R and check for -10 dBV ± 2 dB at LINE OUT R.

3-1. MASTER 1/L-2/R フェーダー (Fig. 3-1)

1. MASTER 1/L-2/Rフェーダーを最大の位置にセットし、SUB INPUT Lに基準レベル信号を入力したとき、LINE OUT Lの出力レベルは -2 ± 2 dBVであること。
2. MASTER 1/L-2/Rフェーダーを 8 dB程絞り、LINE OUT Lの出力レベルが -10 dBVになるようにセットする。
このとき、MASTER 1/L-2/Rフェーダーが網目の位置 (7~8目盛り) にあること。
3. SUB INPUT Rに基準レベル信号を入力したとき、LINE OUT Rの出力レベルは -10 ± 2 dBVであること。

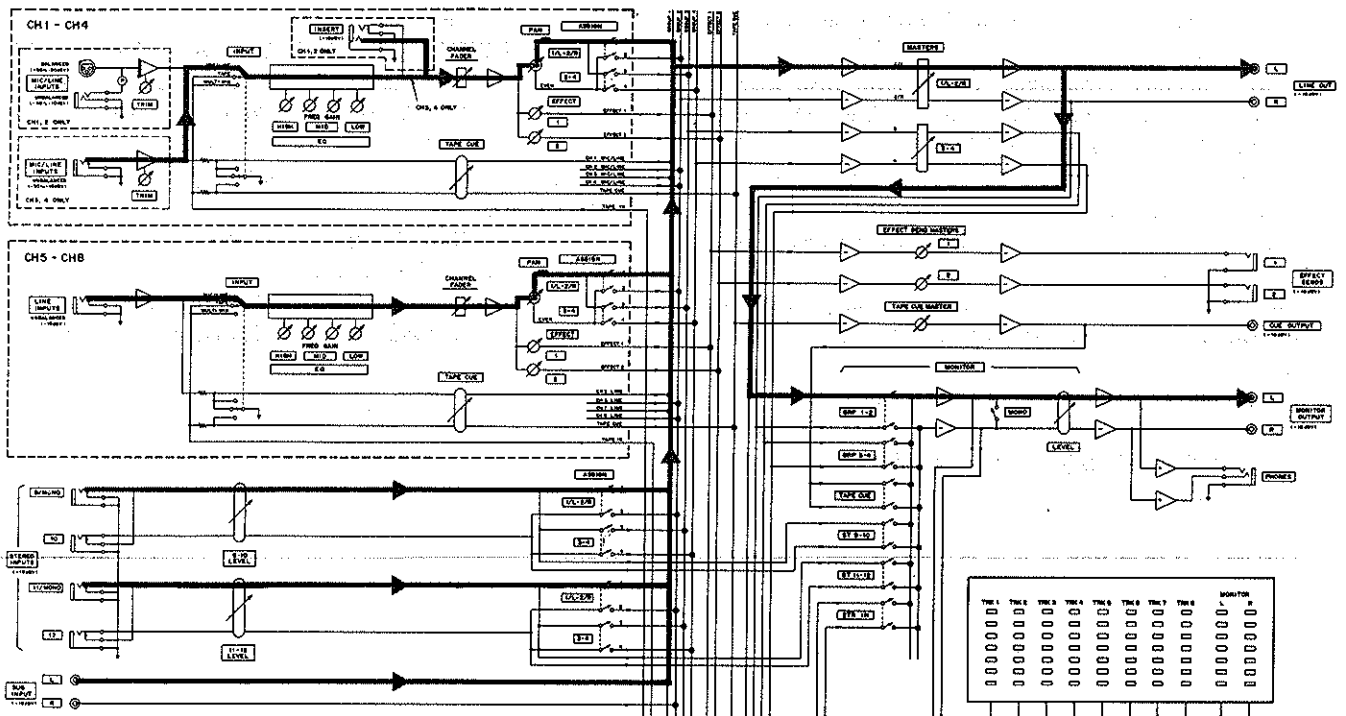

Fig. 3-1

3-2. INPUT Fader on Channels 1 thru 2 (Fig. 3-1)

1. With the MASTER 1/L-2/R fader set to its nominal position, set the ASSIGN 1/L-2/R switch (channel 1) to ON.
2. Turn the PAN (channel 1) all the way to the L position and push the INPUT fader (channel 1) all the way up.
3. Apply a nominal level signal to INSERT 1 and check for -2 ± 3 dBV at LINE OUT L.
4. Pull the INPUT fader (channel 1) until the level reading at LINE OUT L decreases by about 8 dB and is -10 dBV. When you did so, check to see that the INPUT fader (channel 1) is in the shaded area between 7 and 8 on the scale.
5. Turn the PAN (channel 1) all the way to the R position and check for -10 dBV ± 2 dB at LINE OUT R.
6. In a similar way, with the nominal signal applied to the INSERT 2, check for the output level at channel 2.

3-3. INPUT fader on Channels 3 thru 8 (Fig.3-1)

1. Set the TRIM control (channel 3) to its minimum level position (fully to LINE side), INPUT switch (channel 3) to MIC/LINE, ASSIGN 1/L-2/R switch to ON.
2. With the MASTER 1/L-2/R fader set to its nominal position, turn the PAN (channel 3) control all the way to its L position and push the INPUT fader (channel 3) all the way up.
3. Apply a nominal level signal to the MIC/LINE INPUT 3 jack and check for -2 ± 3 dBV at LINE OUT L.
4. Pull the INPUT fader (channel 3) until the level reading at LINE OUT L decreases by about 8 dB and is -10 dBV. When you did so, check to see that the INPUT fader (channel 3) is in the shaded area between 7 and 8 on the scale.
5. Turn the PAN control (channel 3) all the way to its R position and check for -10 ± 2 dBV at LINE OUT R.
6. In a similar way, check for correct output reading when a nominal level signal is fed into MIC/LINE INPUT (LINE INPUT) of each of the remaining channels 4 to 8.

3-2. INPUT フェーダー (CH1~CH2) (Fig. 3-1)

1. MASTER 1/L-2/R フェーダーが基準位置にセットされた状態で、ASSIGN 1/L-2/R スイッチ (CH1) を ON にセットする。
2. PAN つまみ (CH1) を L 側、INPUT フェーダー (CH1) を最大にセットする。
3. INSERT 1 に基準レベル信号を入力したとき、LINE OUT L の出力レベルは -2 ± 3 dBV であること。
4. INPUT フェーダー (CH1) を 8dB 程絞リ、LINE OUT L の出力レベルが -10 dBV になるようにセットする。
このとき、INPUT フェーダー (CH1) が網目の位置 (7~8 目盛り) にあること。
5. PAN つまみ (CH1) を R 側にセットしたとき、LINE OUT R の出力レベルは -10 ± 2 dBV であること。
6. 同様に INSERT 2 に基準レベル信号を入力したときの CH2 の出力レベルを確認する。

3-3. INPUT フェーダー (CH3~CH8) (Fig. 3-1)

1. TRIM つまみ (CH3) を最小 (LINE 側いっぱい) に、INPUT スイッチ (CH3) を MIC/LINE に、ASSIGN 1/L-2/R スイッチを ON にセットにする。
2. MASTER 1/L-2/R フェーダーが基準位置にセットされた状態で PAN つまみ (CH3) を L 側、INPUT フェーダー (CH3) を最大にセットする。
3. MIC/LINE INPUT 3 に基準レベル信号を入力したとき、LINE OUT L の出力レベルは -2 ± 3 dBV であること。
4. INPUT フェーダー (CH3) を 8dB 程絞リ、LINE OUT L の出力レベルが -10 dBV になるようにセットする。
このとき、INPUT フェーダー (CH3) が網目の位置 (7~8 目盛り) にあること。
5. PAN つまみ (CH3) を R 側にセットしたとき、LINE OUT R の出力レベルは -10 ± 2 dBV であること。
6. 同様に CH4 から CH8 迄の各 CH の MIC/LINE INPUT (LINE INPUT) に基準レベル信号を入力して、出力レベルを確認する。

3-4. LEVEL Control on Channels 9 - 10 and 11 - 12 (Fig. 3-1)

• STEREO 9-10

1. With the MASTER 1/L-2/R fader set to its nominal position, set the 9-10 LEVEL control to its maximum position and the 9-10 ASSIGN switch to its 1/L-2/R position.
2. Connect a dummy plug to STEREO INPUT 10 to electronically disconnect the jack.
3. Apply a nominal level signal to STEREO INPUT 9/MONO and check for 0 ± 3 dBV at LINE OUT L.
4. Turn down the 9-10 LEVEL control until the level reading at LINE OUT L decreases by about 10 dB and is -10 dBV. When you did so, check to see that the 9-10 LEVEL control is at about the 2 o'clock position.
5. Removing the dummy plug from STEREO INPUT 10, apply a nominal level signal to the jack and check for -10 ± 2 dBV at LINE OUT R.

• STEREO 11-12

6. In a similar way, set the 11-12 LEVEL control and check for correct output level.

3-5. MONO Input in Channels 9 - 10 and 11 - 12

1. With the 9-10 LEVEL control set to its nominal position, apply a nominal level signal to STEREO INPUT 9/MONO only (with its companion STEREO INPUT 10 jack empty) and check for -10 ± 3 dBV at both L and R of LINE OUTs.
2. In a similar way, apply a nominal level signal to STEREO INPUT 11/MONO only and check for correct output reading.

3-6. MONITOR LEVEL Control (Fig 3-1)

1. After completing settings up to paragraph 3-3's step 4 (the output level at LINE OUT L is -10 dBV), engage only the MONITOR GRP 1-2 switch (all other MONITOR switches should be Off).
2. Turn the MONITOR LEVEL control to its maximum position and check for -2 ± 3 dBV at MONITOR OUTPUT L.
3. Turn down the MONITOR LEVEL control until the level reading at MONITOR OUTPUT L decreases by about 8 dB and is -10 dBV. When you did so, check to see that the MONITOR LEVEL control is at about the 2 o'clock position.
4. Turn the PAN control all the way to its R position and check for -10 ± 2 dBV at MONITOR OUTPUT R

3-4. LEVELつまみ (CH9-10、CH11-12) (Fig. 3-1)

• STEREO 9-10

1. MASTER 1/L-2/Rフェーダーが基準位置にセットされた状態で9-10 LEVELつまみを最大に、9-10 ASSIGNスイッチを1/L-2/Rにセットする。
2. STEREO INPUT 10にダミーのプラグを挿入し、STEREO INPUT 10の入力を切る。
3. STEREO INPUT 9/MONOに基準レベル信号を入力したとき、LINE OUT Lの出力レベルは 0 ± 3 dBVであること。
4. 9-10 LEVELつまみをを10dB程絞り、LINE OUT Lの出力レベルが -10 dBVになるようにセットする。
このとき、9-10 LEVELつまみが2時位の位置にあること。
5. STEREO INPUT 10からダミーのプラグを外し STEREO INPUT 10に基準レベル信号を入力したとき、LINE OUT Rの出力レベルは -10 ± 2 dBVであること。

• STEREO 11-12

6. 同様に11-12 LEVELつまみをセットし、出力を確認する。

3-5. L/MONO チェック (CH9-10、CH11-12)

1. 9-10 LEVELつまみが基準位置にセットされた状態で、STEREO INPUT 9/MONOのみに基準レベル信号を入力したとき、LINE OUT L 及び Rの出力レベルが -10 ± 3 dBVであることを確認する。
2. 同様に、STEREO INPUT 11/MONOのみに基準レベル信号を入力したときの出力レベルを確認する。

3-6. MONITOR LEVELつまみ (Fig. 3-1)

1. 3-3項のステップ4迄のセッティングをした後 (LINE OUT Lの出力レベルが -10 dBV)、MONITORスイッチのGRP 1-2のみをONに、MONITOR MONOスイッチをOFFにセットする。
2. MONITOR LEVELつまみを最大にセットしたとき、MONITOR OUTPUT Lの出力レベルが -2 ± 3 dBVであること。
3. MONITOR LEVELつまみを8dB程絞り、MONITOR OUTPUT Lの出力レベルが -10 dBVになるようにセットする。
このとき、MONITOR LEVELつまみが2時位の位置にあること。
4. PANつまみをR側にセットしたとき、MONITOR OUTPUT Rの出力レベルは -10 ± 2 dBVであること。

3-7. MASTER 3 - 4 Fader (Fig. 3-2)

1. After completing settings up to paragraph 3-6's step 3, set the ASSIGN 3-4 switch to ON (ASSIGN 1-2 switch to OFF) and the MONITOR GRP 3-4 switch only to ON (all other MONITOR switches should be Off).
2. Turn the MASTER 3-4 fader to its maximum position and check for -2 ± 3 dBV at MONITOR OUTPUT L.
3. Pull the MASTER 3-4 fader until the level reading at MONITOR OUTPUT L decreases by about 8 dB and is -10 dBV. When you did so, check to see that MASTER 3-4 fader is in the shaded area between 7 and 8 on the scale.
4. Turn the PAN control all the way to its R position and check for -10 ± 2 dBV at MONITOR OUTPUT R

3-7. MASTER 3-4 フェーダー (Fig. 3-2)

1. 3-6項のステップ3迄のセッティングをした後、ASSIGN 3-4スイッチをONに、(ASSIGN 1-2スイッチをOFFに)、MONITORスイッチのGRP 3-4のみをONにセットする。
2. MASTER 3-4 フェーダーを最大にセットしたとき、MONITOR OUTPUT Lの出力レベルが -2 ± 3 dBVであること。
3. MASTER 3-4 フェーダーを8dB程絞り、MONITOR OUTPUT Lの出力レベルが -10 dBVになるようにセットする。
このとき、MASTER 3-4フェーダーが網目の位置(7~8目盛り)にあること。
4. PANつまみをR側にセットしたとき、MONITOR OUTPUT Rの出力レベルは -10 ± 2 dBVであること。

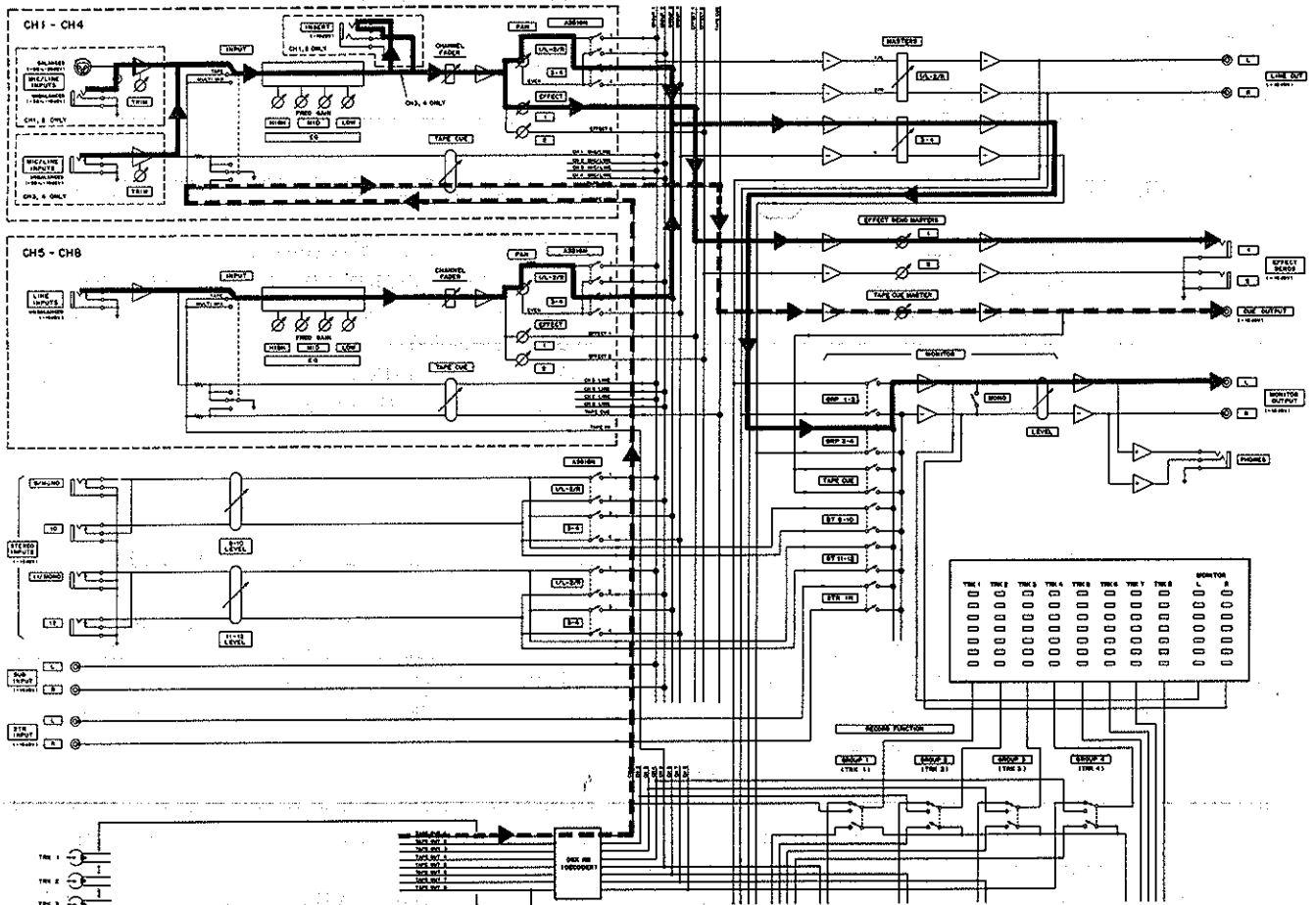

Fig. 3-2

3-8. TAPE CUE MASTER Control (Fig. 3-2)

1. Set the DBX NR switch to OFF and INPUT switch (channel 1) to TAPE.
2. When setting the TAPE CUE control (channel 1) only and TAPE CUE MASTER control to their maximum position, then playing back the TEAC MXT-112 test tape, the output level at CUE OUTPUT should be -6 ± 3 dBV.
3. Turn down the TAPE CUE MASTER control until the level reading at CUE OUTPUT decreases by about 4 dB and is -10 dBV. When you did so, check to see that the TAPE CUE MASTER control is at about the 2 o'clock position.

3-9. EFFECT SEND MASTER Controls (Fig.3-2)

1. Turn the EFFECT 1 and EFFECT SEND MASTER controls to their maximum position.
2. With the INPUT switch set to MIC/LINE (or LINE) and the INPUT fader to its nominal position, apply a nominal level signal to MIC/LINE INPUT (or LINE INPUT) LINE IN and check for -2 ± 3 dBV at EFFECT SEND 1.
3. Turn down the EFFECT SEND MASTER 1 control until the level reading at EFFECT SEND 1 decreases by about 8 dB and is -10 dBV. When you did so, check to see that the EFFECT SEND MASTES 1 control is at about the 2 o'clock position.
4. In a similar way, turn the EFFECT 2 and EFFECT SEND MASTER 2 controls until the level reading at EFFECT SEND 2 is -10 dBV.

3-10. Output Level at MONITOR OUTPUT Jacks

•GRP 1-2

1. After performing step 3 in paragraph 3-6, check for -10 ± 2 dBV at MONITOR OUTPUT L.
2. After performing step 4 in paragraph 3-6, check for -10 ± 2 dBV at MONITOR OUTPUT R.

•GRP 3-4

3. After performing step 3 in paragraph 3-7, check for -10 ± 2 dBV at MONITOR OUTPUT L.
4. After performing step 4 in paragraph 3-7, check for -10 ± 2 dBV at MONITOR OUTPUT R.

•TAPE CUE

5. After performing settings in paragraph 3-8, with the MONITOR LEVEL control set to its nominal position, engage only the MONITOR TAPE CUE switch (all other MONITOR switches should be Off) and check for -10 ± 2 dBV at MONITOR OUTPUT L, R.

3-8. TAPE CUE MASTER つまみ (Fig. 3-2)

1. DBX NRスイッチをOFFに、INPUTスイッチ (CH1) をTAPEにセットする。
2. TAPE CUEつまみ (CH1) のみとTAPE CUE MASTERつまみを最大にセットし、TEAC MXT-112テスト・テープを再生したとき、CUE OUTPUTの出力レベルが -6 ± 3 dBVであること。
3. TAPE CUE MASTERつまみを4dB程絞リ、CUE OUTPUTの出力レベルが -10 dBVになるようにセットする。このとき、TAPE CUE MASTERつまみが2時位の位置にあること。

3-9. EFFECT SEND MASTER つまみ (FIG. 3-2)

1. EFFECT 1つまみ、EFFECT SEND MASTERS 1つまみを最大にセットする。
2. INPUTスイッチがMIC/LINE (又はLINE) に、INPUTフェーダーが基準位置にセットされた状態で、MIC/LINE INPUT (又はLINE INPUT) に基準レベル信号を入力したとき、EFFECT SEND 1の出力レベルが -2 ± 3 dBVであることを確認する。
3. EFFECT SEND MASTER 1つまみを8dB程絞リ、EFFECT SEND 1の出力レベルが -10 dBVになるようにセットする。このとき、EFFECT SEND MASTER 1つまみが2時位の位置にあること。
4. 同様にEFFECT 2つまみとEFFECT SEND MASTER 2つまみでEFFECT SEND 2の出力レベルが -10 dBVになるようにセットする。

3-10. MONITOR OUTPUT 出力のチェック

•GRP 1-2

1. 3-6項、ステップ3をした後、MONITOR OUTPUT Lの出力レベルが -10 ± 2 dBVであること。
2. 3-6項、ステップ4をした後、MONITOR OUTPUT Rの出力レベルが -10 ± 2 dBVであること。

•GRP 3-4

3. 3-7項、ステップ3をした後、MONITOR OUTPUT Lの出力レベルが -10 ± 2 dBVであること。
4. 3-7項、ステップ4をした後、MONITOR OUTPUT Rの出力レベルが -10 ± 2 dBVであること。

•TAPE CUE

5. 3-8項のセッティングをした後、MONITOR LEVELつまみが基準位置にセットされた状態で、MONITORスイッチをTAPE CUEのみONにしたとき、MONITOR OUTPUT L, Rの出力レベルが -10 ± 2 dBVであること。

•ST 9-10

6. After completing settings up to paragraph 3-4's step 5, with the MONITOR LEVEL control set to its nominal position, connect a dummy plug to STEREO INPUT 10 to electronically disconnect the jack, then engage only the MONITOR ST 9-10 switch.
7. Apply the nominal level signal to STEREO INPUT 9, and check for -10 ± 2 dBV at the MONITOR OUTPUT L.
8. Removing the dummy plug from the STEREO INPUT 10 jack, apply the nominal level signal to that jack, then check for -10 ± 2 dBV at the MONITOR OUTPUT R.

•ST 11-12

- As in paragraph "ST 9-10", make checking stated in steps 9 and 10.
9. Engage only the MONITOR ST 11-12 switch, apply the nominal level signal to STEREO INPUT 11/MONO, then check for -10 ± 2 dBV at the MONITOR OUTPUT L.
 10. Apply the nominal level signal to STEREO INPUT 12, then check for -10 ± 2 dBV at the MONITOR OUTPUT R.

•2TR IN

11. With the MONITOR control set to the nominal position, engage only the MONITOR 2TR IN switch.
12. Apply the nominal level signal to the 2TR INPUT L (R) and check that the output level at MONITOR OUTPUT L (R) is -10 ± 2 dBV.

•Monitor Level Meter

13. When doing each setting of the MONITOR switch as instructed in paragraph 3-10, check that the reading of the Monitor Level Meter is 0 dB. Give consideration to the difference between channel L and channel R based on channel L.

3-11. PHONES Output Level

With all input and output controls set to their nominal positions, turn the MONITOR LEVEL control all the way to its maxim position and check for 100 mW or more at PHONES jack under 30 ohm load.

•ST 9-10

6. 3-4項、ステップ5迄のセッティングをした後、MONITOR LEVELつまみが基準位置にセットされた状態で STEREO INPUT 10にダミのプラグを挿入し、MONITORスイッチをST 9-10のみONにする。
7. STEREO INPUT 9に基準レベル信号を入力したとき、MONITOR OUTPUT Lの出力レベルが -10 ± 2 dBVであること。
8. STEREO INPUT 10からダミのプラグを外して同端子に基準レベル信号を入力したとき、MONITOR OUTPUT Rの出力レベルが -10 ± 2 dBVであること。

•ST 11-12

- ST 9-10項と同じ要領でステップ9、10のチェックをする。
9. MONITORスイッチをST 11-12のみONにして、STEREO INPUT 11/MONOに基準レベル信号を入力したとき、MONITOR OUTPUT Lの出力レベルが -10 ± 2 dBVであること。
 10. STEREO INPUT 12に基準レベル信号を入力したとき、MONITOR OUTPUT Rの出力レベルが -10 ± 2 dBVであること。

•2TR IN

11. MONITORつまみが基準位置にセットされた状態で MONITORスイッチを2TR INのみONにする。
12. 2TR INPUT L (R)に基準レベル信号を入力したとき、MONITOR OUTPUT L (R)の出力レベルが -10 ± 2 dBVであること。

•モニター・レベル・メーター

13. 3-10項のMONITORスイッチの各セッティングをしたとき、モニター・レベル・メーターが0dBを指示することを確認する。但しL-CHを基準としL-CHとR-CHの差を考慮すること。

3-11. PHONES出力のチェック

1. 基準入出力状態で、MONITOR LEVELつまみを最大にしたとき、PHONES端子に30Ω負荷で100mW以上の出力があること。

3-12. MIC IN

•Unbalanced Type

1. Set the PHANTOM POWER switch to OFF, the INPUT switch to MIC/LINE, the ASSIGN 1/L-2/R switch to ON. Turn the PAN control fully to L (R) side for measuring at LINE OUT L (R) jack.
2. With the INPUT and MASTER 1/L-2/R faders set their nominal positions, apply the nominal level signal to MIC/LINE INPUT (Unbalanced) then adjust the TRIM control so that the output level at the LINE OUT L (R) is -10 dBV.
3. Apply the -50 dBV to the MIC/LINE INPUT (Unbalanced), turn the TRIM control fully to its maximum position (fully to MIC side) and check for -10 dBV or more at LINE OUT L (R).

•Balanced Type

4. Apply the -20 dBV (1 kHz) signal to MIC/LINE INPUT (Balanced) then adjust the TRIM control so that the output level at the LINE OUT L (R) is -10 dBV.
5. Apply the -60 dBV to the MIC/LINE INPUT (Balanced), turn the TRIM control fully to its maximum position (fully to MIC side) and check for -10 dBV or more at LINE OUT L (R).

3-13. Frequency Response

With all input and output controls set to their nominal positions, check that the frequency response for the following signal paths is within the limits:

MIC IN - LINE OUT, MONITOR OUT	20Hz~20kHz +1, -3dB
LINE IN - LINE OUT, MONITOR OUT	20Hz~20kHz +1, -3dB
LINE IN - EFFECT SEND	20Hz~20kHz +1, -3dB
LINE IN - PHONES	40Hz~20kHz +1, -3dB

3-14. Distortion

With all input and output controls set to their nominal positions, check for: (20 Hz to 20 kHz, the 400 Hz and 30 kHz filters inserted)

- 1 LINE IN - LINE OUT: 0.05% or less
(at 1 kHz, nominal level input)
- 1 MIC IN - LINE OUT: 0.05% or less
(at 1 kHz, 15 dB above nominal input level)

3-15. Signal-to-Noise Ratio

With all input and out controls set to their nominal positions, check for: (DIN AUDIO)

- 1 MIC IN - LINE OUT: 64 dB or better
- 4 MIC INs - LINE OUT: 58 dB or better
- 1 LINE IN - LINE OUT: 79 dB or better
- 8 LINE INs - LINE OUT: 75 dB or better

3-12. MIC入力のチェック

•アンバランス・タイプ

1. PHANTOM POWERスイッチをOFFに、INPUTスイッチをMIC/LINEに、ASSIGN 1/L-2/RスイッチをONにする。PANつまみはLINE OUT L (R) 端子での測定の際はL (R) 側いっぱいに戻す。
2. INPUTフェーダーとMASTER 1/L-2/Rフェーダーが基準位置にセットされた状態で、MIC/LINE INPUT (Unbalanced) に基準レベル信号を入力し、LINE OUT L (R) の出力が-10dBVとなるようにTRIMつまみを調整する。
3. MIC/LINE INPUT (Unbalanced) に-50dBVを入力し、TRIMつまみを最大 (MIC側いっぱい) にしたとき、LINE OUT L (R) から-10dBV以上出力することを確認する。

•バランス・タイプ

4. MIC/LINE INPUT (Balanced) に-20dBV (1kHz) を入力し、LINE OUT L (R) の出力が-10dBVとなるようにTRIMつまみを調整する。
5. MIC/LINE INPUT (Balanced) に-60dBVを入力し、TRIMつまみを最大 (MIC側いっぱい) にしたとき、LINE OUT L (R) から-10dBV以上出力することを確認する。

3-13. 周波数特性

基準入出力状態に於いて、下記のINPUTからOUTPUTへの周波数特性は以下の通りです。

MIC IN - LINE OUT, MONITOR OUT	20Hz~20kHz +1, -3dB
LINE IN - LINE OUT, MONITOR OUT	20Hz~20kHz +1, -3dB
LINE IN - EFFECT SEND	20Hz~20kHz +1, -3dB
LINE IN - PHONES	40Hz~20kHz +1, -3dB

3-14. 歪率

各系統の入出力つまみが基準位置にセットされた状態で測定します。(20Hz~20kHz, 400Hz, 30kHzフィルターを使用)

- 1 LINE IN - LINE OUT 0.05%以下
(1kHz基準入力レベルを入力)
- 1 MIC IN - LINE OUT 0.05%以下
(1kHz、基準入力より15dB高いレベルを入力)

3-15. S/N

各系統の入出力つまみが基準位置にセットされた状態で測定します。(DIN AUDIO)

- 1 MIC IN - LINE OUT 64dB以上
- 4 MIC IN - LINE OUT 58dB以上
- 1 LINE IN - LINE OUT 79dB以上
- 8 LINE IN - LINE OUT 75dB以上

4. AMPLIFIER CHECKS AND ADJUSTMENTS

録音・再生アンプ部のチェックと調整

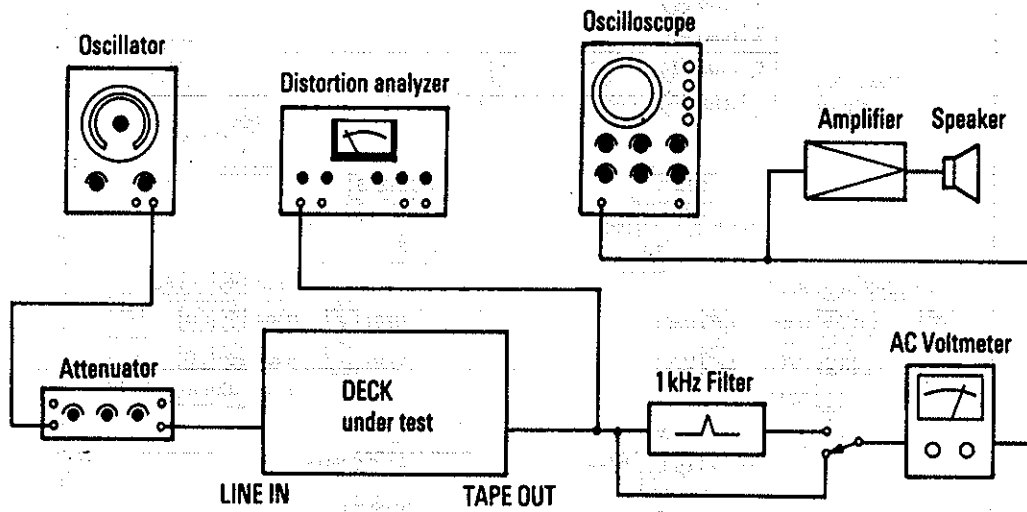

Fig. 4-1 Basic test setup

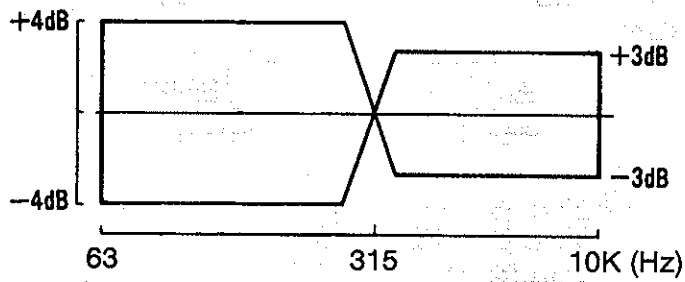

Fig. 4-2 Playback frequency response

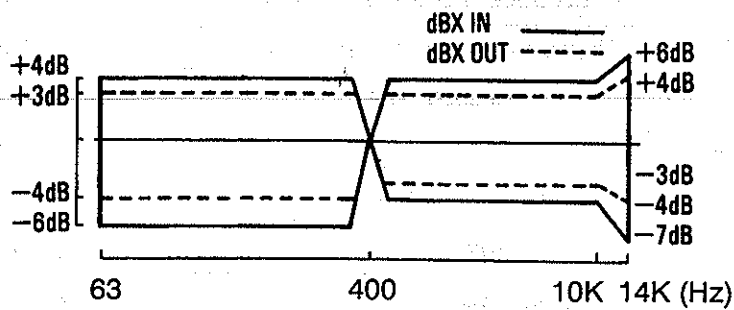
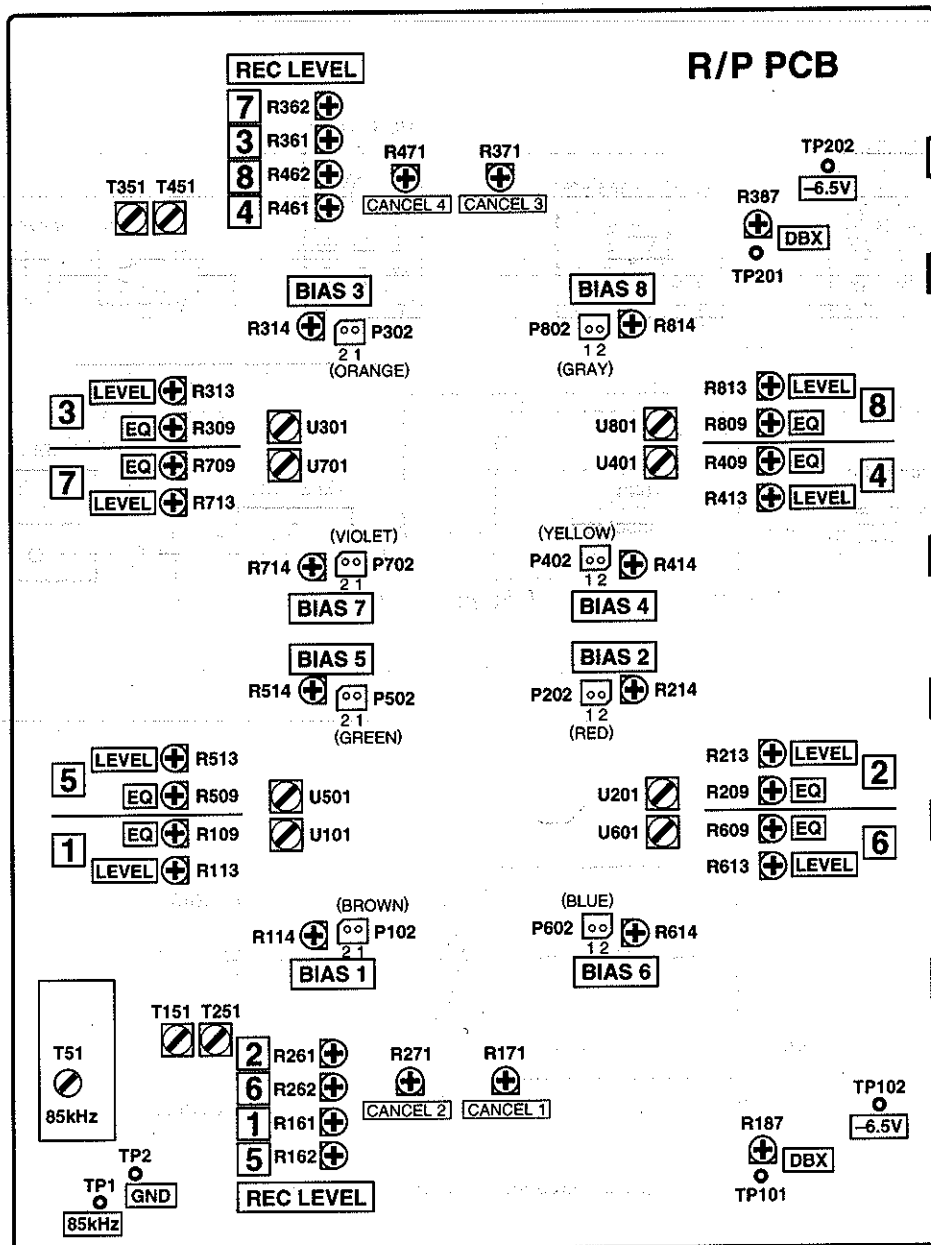

Fig. 4-3 Overall frequency response



R109~R809	Reproduce Frequency Level	再生周波数特性
R113~R813	Reproduce Reference Level	再生基準レベル
R114~R814	Record Bias	録音バイアス
R161・162~R461・462	Record Level	録音レベル
R171~R471	Sync Cross-talk Cancel	シンク・クロストーク・キャンセル
R187 (R387)	dbx Timing	dbx タイミング
T51	Bias OSC. Frequency	バイアス発振周波数
T151~T451	Bias Amp. (Erase)	バイアス・アンプ (消去)
U101~U801	Reproduce Bias Trap	再生バイアス・トラップ

Fig. 4-4 Adjustments and Test Points

4-1. General Notes

1. Before adjusting amplifiers, thoroughly demagnetize and clean the erase head, the rec/repro head and the tape path.
2. Use a level meter with an input impedance of more than 1M-ohm.
3. For blank tape, use TEAC MTT-5562 or equivalent tapes.
4. 0 dBV corresponds to 1 Volt.
5. The output load impedance should be 10 k Ω , unless otherwise noted.
6. Unless otherwise specified, first adjust channel 1 then other channels in sequence. Indication, for example, "R113 (R213 to R813)" means that R113 is for channel 1, R213 for channel 2, R313 for channel 3, and set on.

4-2. Reproduce Systems

Test Mode: PLAY

Measurement point: CUE OUTPUT Jack

Adjustment Item	Preliminary Setting	Input Signal	Adjustment Point	Measurement Point/Value Adjusted for	Remark
1. Repro Reference Level	Connect equipment as shown in Fig. 4-1.	MXT-112	R113 (R213 to R813)	Each ch. : -10 dBV (± 1.5 dB)	
2. Meter Calibration	Voltmeter connected between TP1 and TP4 (AMP GND) on CONTROL PCB		R5 on CONTROL PCB (Fig. 2-7)	4.2 V at TP1 The meter read should read 0 dB.	
3. Repro Frequency Response	Same as above	MXT-1161	R109 (R209 to R809)	Specs shown in Fig. 4-2. 0 dB for 10 kHz (same level as for 315 Hz)	
4. Level Difference between Channels	Same as above	Same as above	Check only	Each ch. : within 3 dB over 63 Hz - 10 kHz	
5. Level Fluctuation	Same as above	Same as above	Same as above	Each ch. : within 2 dB over 63 Hz - 6.3 kHz within 3 dB over 6.3 kHz - 10 kHz	
6. Repro S/N Ratio	Same as above		Same as above	Measure the output when leader tape is played back with the unit set for nominal output, and compare that reading with nominal level. Level difference (DIN-AUDIO) 46 dB or greater (44 dB or greater for channels 1 and 8) Level difference between channels : 4 dB or less	

4-3. Recording Systems

Test Mode: REC/PLAY (except otherwise specified)

Signal Input: LINE INPUT Jack

Measurement Point: CUE OUTPUT Jack
(except otherwise specified)

Adjustment Item	Preliminary Setting	Input Signal	Adjustment Point	Measurement Point/ Value Adjusted for	Remark
1. Bias Oscillator Frequency	Frequency counter connected between TP1 and TP2 (GND); RECORD FUNCTION turned ON on ch. 1-4; Transport in REC/PAUSE	-	T51	85 ± 2 kHz at T51	
2. Bias Amp (Erase)	Oscilloscope connected between pin 1 on P102 (P202~P402) and GND; RECORD FUNCTION turned ON on ch. 1 (2 to 4); Transport in REC/PAUSE	-	T151 (T251 to T451)	Adjust so peak value at P102 (P202 to P402) is at a maximum. When REC FUNC. SW is set to ch. 5 (ch. 6 to ch. 8); see that peak value at P502 (P602 to P802) is nearly at the same level as above peak value.	
3. Record Bias	Connected as in Fig. 4-1; dbx NR switched IN	-30 dBV (20 dBV below nominal input level)	R114 (R214 to R814)	Same level for 400 Hz and 10 kHz as read off tape during recording.	
4. Bias Trap	Connected as in Fig. 4-1	No signal	U101 (U201 to U801)	Adjustment ch. in repro, the adjacent ch. in record; Adjust U201 for minimum bias leakage from ch. 1 in record into ch. 2 in repro. Similarly, adjust the following: U101 (ch. 2 to 1); U401 (ch. 3 to 4); U301 (ch. 4 to 3); U601 (ch. 5 to 6); U501 (ch. 6 to 5); U801 (ch. 7 to 8); U701 (ch. 8 to 7)	
5. dbx Timing	DC voltmeter connected between TP101 and TP102 (TP201 and TP202)	-	R187 (R387)	18.4 mV as read on the voltmeter	
6. Record Reference Level (with dbx)	Connected as in Fig. 4-1; dbx NR switched IN	400 Hz, -10 dBV (nominal input level)	R161 & R162 (R261 & R262 to R461 & R462)	-10 dBV output as read off tape during recording (tolerance: -10 ± 3 dB; ±1 dot on the peak level meter on the unit.)	
7. Record Reference Level (without dbx)	Connected as in Fig. 4-1; dbx NR switched OUT	Same as above	Check only	-10 ± 3 dBV output as read off tape during recording (±1 dot on the peak level meter on the unit.)	
8. Record Distortion	Same as above	Same as above	Check only	2% or less for every ch. (2.4% or less for channels 1 and 8)	
9. Rec/Repro Frequency Response	Connected as in Fig. 4-1; dbx NR alternately switched IN and OUT	63 Hz to 14 kHz, -30 dBV (-20 dB below nominal input level)	Check only	Specs shown in Fig. 4-3	
10. Level Difference between Channels	Connected as in Fig. 4-1 dbx NR switched OUT	Same as above	Check only	Level difference between channels within tolerance of the specified rec/repro frequency response: less than 3 dB over 63 Hz to 6.3 kHz; less than 4 dB (except for between ch. 1 and 8) over 6.3 kHz to 10 kHz	

Adjustment Item	Preliminary Setting	Input Signal	Adjustment Point	Measurement Point/ Value Adjusted for	Remark
11. Rec/Repro Level Fluctuation	Same as above	Same as above	Check only	Level fluctuation between channels within tolerance of the specified rec/repro frequency response; less than 1 dB (less than 2 dB between ch. 1 and 8) at 400 Hz; less than 2 dB (less than 3 dB between ch. 1 and 8) over 63 Hz to 6.3 kHz; less than 3 dB (less than 4 dB between ch. 1 and 8) over 6.3 kHz to 14 kHz	
12. Sync Crosstalk Suppression	Connected as in Fig. 4-1; RECORD FUNCTION: ON for channel under test; OFF for all other channels	10 kHz, -10 dBV	R171 (R271 to R471)	Minimum signal leakage from the recording channel under test into its adjacent reproducing channel. (Level difference between the two channels should be less than 0 dB)	
13. Crosstalk between Tracks	Connected as in Fig. 4-1; RECORD FUNCTION: ON for ch. 1-4 (5-8)	ch. 1-4: 125 Hz, -10 dBV; ch. 5-8: no signal	Check only	Record the input signal, then rewind and play the recording. Compare the output of ch. 1-4 with that of ch. 5-8. Level difference: 30 dB or greater. Repeat the check with the test signal (125 Hz, -10 dBV) connected to ch. 5-8 and no signal to ch. 1-4.	
14. Channel Separation	Connected as in Fig. 4-1 (1 kHz B.P.F. inserted); RECORD FUNCTION: ON for ch. 1-4: (5-8)	ch. 1, 3: 1 kHz, -10 dBV; ch. 2, 4: no signal	Check only	Record the input signal, then rewind to play the recording. Compare the output of ch. 1 and 3 with that of ch. 2 and 4. Level difference: 35 dB or greater. Repeat the check for the following combination of channels: ch. 2 and 4→ch. 1 and 3; ch. 5 and 7→ch. 6 and 8; ch. 6 and 8→ch. 5 and 7	
15. Cross Erasure	Connected as in Fig. 4-1	ch. 1-4: 10 kHz, -10 dBV; ch. 5-8: no signal	Check only	Record using ch. 1-4 and play the recording to measure the output level. Then, erase tracks 5-8, and measure again the output of ch. 1-4, to check for level degradation of less than 1.5 dB Repeat the check with the test signal (10 kHz, -10 dBV) connected to ch. 5-8 and no signal to ch. 1-4.	
16. Erasure	Connected as in Fig. 4-1 (1 kHz B.P.F. inserted)	1 kHz, 0 dBV (10 dB above nominal input level)	Check only	Erase a part of the recorded section, and play the tape to compare the level from the remaining recorded section with the level from the erased section. Level difference: 65 dB or greater	
17. Rec/Repro Signal-to-Noise Ratio	Connected as in Fig. 4-1; dbx NR switched OUT	No signal	Check only	Compare the output from the "no-signal" recording with nominal output level. Level difference (DIN-AUDIO): 44 dB or greater (42 dB or greater for ch. 1 and 8) Difference between channels: 4 dB or less.	

4-1. 注意

1. アンプ部の調整の前に、消去ヘッド、録/再ヘッド、テープ走行部分を充分消磁し、クリーナ液で清掃して下さい。
2. レベル計は入力インピーダンス1M Ω 以上のものを使用して下さい。
3. ブランク・テープは、TEAC MTT-5562又は相当品を使用して下さい。
4. 0dBV = 1Vで示しています。
5. 出力負荷インピーダンスは注記の無い限り10k Ω とする。
6. 特に指定の無い限り、調整はCH1から順番に行って下さい。
R113 (R213~R813) と記されている調整ボリュームの部番は、CH1 (CH2~CH8) を示します。

4-2. 再生系

モード: PLAY

測定箇所: CUE OUTPUT 端子

調整項目	準備・設定	入力信号	調整箇所	測定箇所・調整値	備考
1. 再生基準レベル	接続: Fig. 4-1	MXT-112	R113 (R213~R813)	各ch: -10dBV (± 1.5 dB)	
2. メータ・レベル	CONTROL PCB上のTP1-TP4 (AMP GND) 間に電圧計を接続	-	CONTROL PCB上のR5 (Fig. 2-7)	TP1の電圧が4.2Vとなるように調整 メータ指示は0dBのこと。	
3. 再生周波数特性	同上	MXT-1161	R109 (R209~R809)	各ch: 規格: Fig. 4-2 10kHzのレベルが0dB (315Hzと同レベル) となるように調整	
4. チャンネル間レベル差	同上	同上	チェック	各ch: 63Hz~10kHz: 3dB以内	
5. レベル変動	同上	同上	同上	各ch: 63Hz~6.3kHz: 2dB以内 6.3kHz~10kHz: 3dB以内	
6. 再生S/N比	同上	-	同上	基準出力状態でリーダーテープ部を再生したときの値と基準出力との比 (DIN AUDIO) 各ch: 46dB以上 (但し、1、8chは44dB以上) チャンネル差 4dB以内	

4-3. 録音系

モード：REC/PLAY (特に指示のある場合を除く)

信号入力：LINE INPUT 端子

測定箇所：CUE OUTPUT 端子 (特に指示のある場合を除く)

調整項目	準備・設定	入力信号	調整箇所	測定箇所・調整値	備考
1. バイアス発信周波数	接続：TP1 - TP2 (GND) 端子間に周波数カウンターを接続 REC FUNC. SW : 1~4ch ON REC/PAUSE 状態	-	T51	T51 で周波数が $85 \pm 2\text{kHz}$ になるように調整	
2. バイアス・アンプ (消去)	接続：P102 (P202~P402) の1番ピンとGND間にオシロスコープを接続 REC FUNC. SW : 1 (2~4ch) ON REC/PAUSE 状態	-	T151 (T251~T451)	P102 (P202~P402) の波高値が最大になるように調整 REC FUNC. SW を5ch (6~8ch) に切り替えたとき P502 (P602~P802) の波高値が上記の波高値とほぼ同一であることを確認する。	
3. 録音バイアス	接続：Fig. 4-1 dbx NR : IN	-30dBV (基準入力に対して-20dB)	R114 (R214~R814)	録音・再生したとき、400Hzと10kHzが同レベルとなるように調整	
4. バイアス・トラップ	接続：Fig. 4-1	無信号	U101 (U201~U801)	調整ch : 再生、隣接ch : 録音 1ch 録音時、2ch へのBIAS漏れが最小になるようにU201を調整 以下同様に 2ch → 1ch : U101 3ch → 4ch : U401 4ch → 3ch : U301 5ch → 6ch : U601 6ch → 5ch : U501 7ch → 8ch : U801 8ch → 7ch : U701	
5. dbx タイミング	接続：TP101とTP102 (TP201とTP202) 間に直流電圧計を接続	-	R187 (R387)	TP101とTP102 (TP201とTP202) 間の電圧が18.4mVになるように調整	
6. 録音基準レベル (dbx NR : IN)	接続：Fig. 4-1 dbx NR : IN	400Hz/-10dBV (基準入力)	R161・R162 (R261・R262~ R461・R462)	録音・再生したとき、-10dBVの出力が出るように調整 (-10 ± 3dB) 但し、このとき本体のメーターは±1ドットのこと	
7. 録音基準レベル (dbx NR : OUT)	接続：Fig. 4-1 dbx NR : OUT	同上	チェック	録音・再生したとき、-10 ± 3dBVの出力があること。 又、このとき本体のメーターは±1ドットのこと	
8. 録再歪率	同上	同上	チェック	各ch : 2%以下 但し1ch、8chは2.4%以下	
9. 録再周波数特性	接続：Fig. 4-1 dbx NR : IN, OUT	63Hz~14kHz/-30dBV (基準入力に対して-20dB)	チェック	各ch : 規格 Fig. 4-3	
10. チャンネル間レベル差	接続：Fig. 4-1 dbx NR : OUT	同上	チェック	録再周波数特性規格内に於けるch間レベル差 63Hz~6.3kHz : 3dB以内 6.3kHz~10kHz : 4dB以内 (1、8chは除く)	
11. 録再レベル変動	同上	同上	チェック	録再周波数特性規格内に於けるレベル変動 400Hz : 1dB以内 (1、8chは2dB以内) 63Hz~6.3kHz : 2dB以内 (1、8chは3dB以内) 6.3kHz~14kHz : 3dB以内 (1、8chは4dB以内)	

調整項目	準備・設定	入力信号	調整箇所	測定箇所・調整値	備考
12. シンク・クロストーク・キャンセル	接続: Fig. 4-1 REC FUNCTION SW: 調整chのみ ON 他ch OFF	10kHz/-10dBV	R171 (R271~R471)	調整chのみ録音状態にしたとき、隣接再生chへの漏れが最小となるように調整 (基準レベルに対する漏れのレベルの比が0dB以下のこと)	
13. トラック間クロストーク	接続: Fig. 4-1 REC FUNCTION SW: 1~4ch ON (5~8ch ON)	1~4ch: 125Hz/-10dBV 5~8ch: 無信号	チェック	録音部分を巻き戻して再生したとき、1~4chの再生出力と5~8chの再生出力との比 30dB以上 以下 1~4ch: 無信号 5~8ch: 125kHz/-10dBV の場合も同様にチェックする。	
14. チャンネル・セパレーション	接続: Fig. 4-1 (1kHz B.P.F.使用) REC FUNCTION SW: 1~4ch ON (5~8ch ON)	1, 3ch: 1kHz/-10dBV 2, 4ch: 無信号	チェック	録音部分を巻き戻して再生したとき、1, 3chの再生出力と2, 4chの再生出力との比 35dB以上 以下 2, 4ch→1, 3ch 5, 7ch→6, 8ch 6, 8ch→5, 7chの場合も同様にチェックする。	
15. クロス消去	接続: Fig. 4-1	1~4ch: 10kHz/-10dBV 5~8ch: 無信号	チェック	1~4chを録音、再生したときのレベルを確認後、5~8chを消去したとき、1~4chの再生レベルの低下 1.5dB以内 以下 1~4ch: 無信号 5~8ch: 10kHz/-10dBV の場合も同様にチェックする。	
16. 消去率	接続: Fig. 4-1 (1kHz B.P.F.使用)	1kHz/0dBV (基準レベルに対して + 10dB)	チェック	録音部分の一部を残して消去した後、再生したときの未消去部分との差 65dB以上	
17 録再S/N	接続: Fig. 4-1 dbx NR: OUT	無信号	チェック	基準出力レベルと無信号録音再生したノイズレベルとの比 (DIN - AUDIO) 44dB以上 (但し、1, 8chは42dB以上) チャンネル差: 4dB以内	

EXPLODED VIEW -1

REF. NO.	PARTS NO.	DESCRIPTION	REMARKS
1- 1	M00004200A	KNOB, PITCH GY	
1- 2	*E95007400A	R/P PCB ASSY	Refer to pages 35 and 43
1- 3	*M00005000A	SHIELD SHEET, RP	
1- 4	*E95007600A	JOINT POWER PCB ASSY	Refer to pages 39 and 44
1- 5	*E95008400A	DBX PCB ASSY	Refer to pages 37 and 44
1- 6	*E95010300A	FL PCB ASSY	Refer to pages 36 and 44
1- 7	*E95010200A	JOINT FL-PCB AASY	Refer to pages 39 and 44
1- 8	*E95010100A	CONTROL PCB ASSY	Refer to pages 32 and 42
1- 9	*E95007500A	POWER PCB ASSY	Refer to pages 34 and 42
1-10	*E90010700A	TR C PCB ASSY	Refer to pages 32 and 42
1-11	*E95010500A	TR A PCB ASSY	Refer to pages 32 and 42
1-12	*E95010600A	TR B PCB ASSY	Refer to pages 32 and 42
1-13	*M00190200A	SHIELD SHEET, DBX	
1-14	*M00004600A	HEATSINK	
1-15	*M00004500A	SHIELD SHEET, CONT	
1-16	*M00004800A	SHIELD PLATE, TRANS.	
1-17	△ E00000000A	TRANS, POWER	
1-18	5801503800	BUTTON, POWER(P-N15-A)	
1-19	*E95008000A	TRANS PCB ASSY	Refer to pages 36 and 43
1-20	*M00069200A	VINYL SHEET, TRANS.	
1-21	△ 5350015200	CORD, AC DM [J]	
	△ 5350019500	CORD, AC UL/CSA SPT-2 [US/C]	
	△ 5350017500	CORD, AC EUR CLASS 2 [E]	
	△ E00120800A	CORD, AC BS 5A W/PLUG [UK]	
	△ 5350018200	CORD, AC SAA [A]	
1-22	△ *5317003400	BUSHING, 2271	
1-23	*M00004700A	BRACKET, BUSHING	
1-24	*M00005100A	BRACKET, FL	
1-25	*E95010400A	PITCH CONTROL PCB ASSY	Refer to pages 41 and 45
1-26	M00238400A	FOOT	
1-27	*M00043000A	CABINET, BOTTOM	
1-28	*M00004400A	BRACKET, TRANS.	
1-29	*5800673000	HEAT SINK	
1-41	*5780022608	SCREW, BIND M2. 6X8 (BLK)	
1-42	*5783603008	SCREW, P-TITE BIND M3X8	
1-43	*5786713400	CLIP, HARNESS 3. 2X6. 0X47	
1-44	*B00001600A	SCREW, 3X8CPN	
1-45	*5783004018	SCREW, S-TITE PAN M4X18	
1-46	*5783073018	SCREW, CUP S-TITE PAN M3X18	
1-47	*5783033006	SCREW, S-TITE BIND M3X6	
1-48	*5783693010	SCREW, S-TITE BIND M3X10 (BLK)	
1-49	*5783543020	SCREW, P-TITE BIND M3X20 (BLK)	
1-50	*5783603030	SCREW, P-TITE BIND M3X30	
1-51	*B00019500A	SCREW, P-TITE BIND 2. 6X3X7	
1-52	*5785013000	WASHER, M3 TO. 5	

INCLUDED ACCESSORIES

REF. NO.	PARTS NO.	DESCRIPTION	REMARKS
	D00089900A	OWNERS MANUAL, J [J]	
	D00090000A	OWNERS MANUAL, E [US/C, E, UK, A]	
	D00090100A	OWNERS MANUAL, F/G/I [C, E]	

EXPLODED VIEW-2

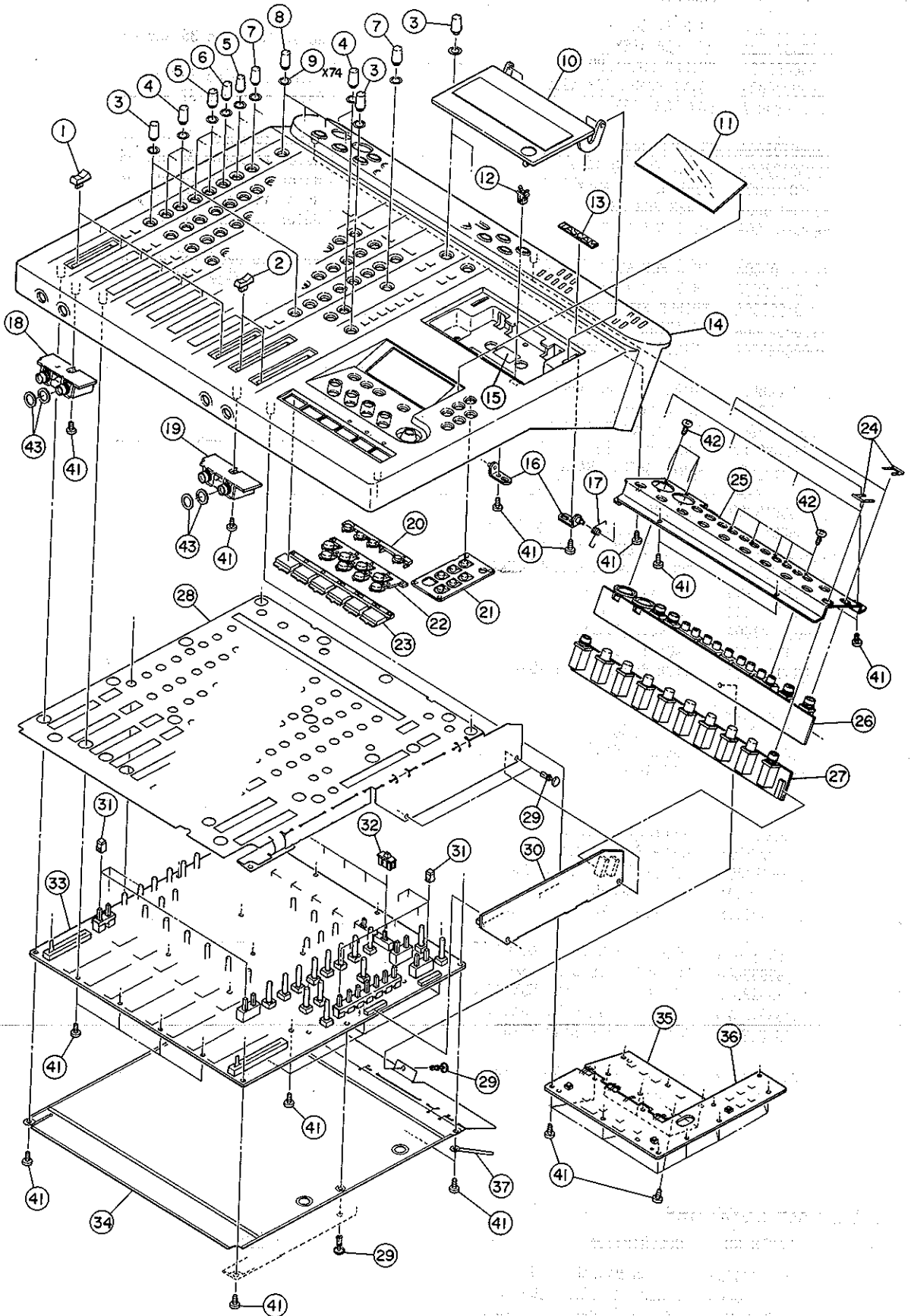

EXPLODED VIEW -2

REF. NO.	PARTS NO.	DESCRIPTION	REMARKS
2- 1	M00004000A	KNOB, FADER OG	
2- 2	M00004001A	KNOB, FADER RD	
2- 3	M00003902A	KNOB, WT	
2- 4	M00003901A	KNOB, GN	
2- 5	M00003900A	KNOB, BU	
2- 6	M00003905A	KNOB, PP	
2- 7	M00003903A	KNOB, OG	
2- 8	M00003904A	KNOB, RD	
2- 9	*M00203600A	WASHER, 8. 3X11. 7X0. 3	
2-10	5801393600	COVER, CASSETTE	
2-11	*M00005200A	WINDOW	
2-12	5801277700	LATCH	
2-13	*5801634100	BADGE, TASCAM	
2-14	*M00003000A	CABINET, TOP	
2-15	*5800822400	REFLECTING MIRROR(A)	
2-16	*5801400200	BRACKET ASSY, CASSETTE COVER	
2-17	5801393000	SPRING, UP	
2-18	*E95008200A	INSERT PCB ASSY	Refer to pages 40 and 45
2-19	*E95008100A	PHONE PCB ASSY	Refer to pages 39 and 45
2-20	M00003300A	BUTTON, RST GY	
2-21	M00003500A	BUTTON, DSP GY	
2-22	M00003400A	BUTTON, FUN GY	
2-23	M00003200A	BUTTON, OPE GY	
2-24	*5317005800	PLATE S, MOUNT	
2-25	*M00003800A	BRACKET, JACK	
2-26	*E95007800A	I/O PCB ASSY	Refer to pages 39 and 44
2-27	*E95007700A	INPUT PCB ASSY	Refer to pages 39 and 44
2-28	*M00003700A	SHIELD SHEET, MIXER T	
2-29	5534878000	RIVET, PUSH RP-3545-NB	
2-30	*E95008500A	JOINT MIXER PCB ASSY	Refer to pages 38 and 44
2-31	M00004100A	BUTTON, GY	
2-32	M00006100A	KNOB, SLIDE GY	
2-33	*E95007300A	MIXER PCB ASSY	Refer to pages 33 and 42
2-34	*M00069300A	SHIELD SHEET, MIXER B	
2-35	*E95009900A	SW A PCB ASSY	Refer to pages 36 and 43
2-36	*E95010000A	SW B PCB ASSY	Refer to pages 41 and 45
2-37	*5786713400	CLIP, HARNESS 3. 2X6X47	
2-41	*5783603008	SCREW, P-TITE BIND M3X8	
2-42	*5783543008	SCREW, P-TITE BIND M3X8 (BLK)	
2-43	*M00252400A	WASHER, 10. 3X14X0. 3	

EXPLODED VIEW-3

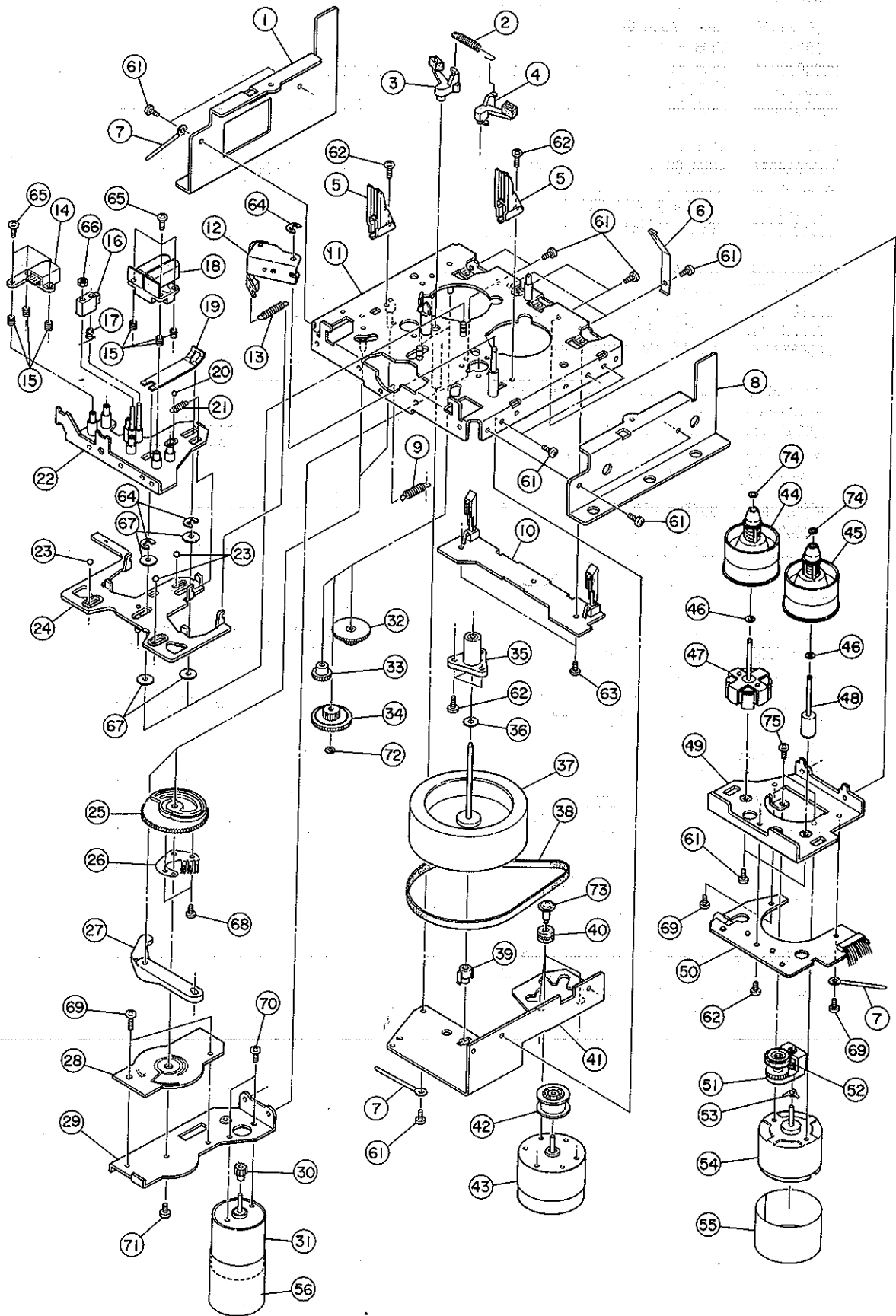

EXPLODED VIEW -3

REF. NO.	PARTS NO.	DESCRIPTION	REMARKS
3- 1	*5801470900	PLATE L, MECHA.	
3- 2	*5801475700	SPRING, BRAKE	
3- 3	5801475300	BRAKE ARM(L) ASSY	
3- 4	5801475500	BRAKE ARM(R) ASSY	
3- 5	*5801197100	GUIDE(U), CASSETTE	
3- 6	5801197200	SPRING(U), HALF PRESSURE	
3- 7	*5786713400	CLIP, HARNESS 3. 2X6. 0X47	
3- 8	*5801471000	PLATE R, MECHA.	
3- 9	*5801476200	SPRING, BASE ARM	
3-10	*5200363520	SW (E) PCB ASSY	Refer to pages 41 and 45
3-11		CHASSIS ASSY, MECHA.	
3-12	5800955400	PINCH ROLLER ARM ASSY(R)	6320-62
3-13	5800955800	SPRING(R), PINCH ROLLER	
3-14	5378602200	HEAD, ERASE 8-8	
3-15	*5800931300	SPRING, HEAD	
3-16	5801091300	GUIDE, TAPE	
3-17	5801091200	SPRING, TAPE GUIDE	
3-18	5378602300	HEAD, R/P 8-8 20 20 & 6	
3-19	*5801481400	SPRING, PRESSURE	
3-20	5540055000	STEEL BALL, 2 φ	
3-21	*5801005700	SPRING, HEAD BASE	
3-22	*M00017700A	HEAD BASE ASSY, 8	
3-23	*5540056000	STEEL BALL, 3 φ	
3-24	*5801475000	SLIDER ASSY	
3-25	5801474600	CAM, CONTROL	
3-26	M00070800A	PLATE, CAM CONTACT	
3-27	*5801474800	ARM, BASE	
3-28	5210334000	PCB, CAM	
3-29	*5801474000	BRACKET, ASSIST MOTOR	
3-30	5801474400	GEAR, MOTOR	
3-31	5370010300	DC MOTOR, ASSIST MXN-13FB12F	
3-32	5801474300	GEAR, C	
3-33	5801474101	GEAR, A	
3-34	5801474200	GEAR, B	
3-35	5800732100	METAL HOLDER ASSY	
3-36	5800735300	WASHER, THRUST	
3-37	5801204400	CAPSTAN ASSY (L62)	
3-38	5800735500	BELT, CAPSTAN	672101
3-39	5801198100	PLATE(F), THRUST	
3-40	5534537001	GROMMET, NON-VIBRATION	
3-41	*5801204600	PLATE(B), FLYWHEEL	
3-42	5801198200	PULLEY, CASPSTAN 12.7 φ	
3-43	5370008700	MOTOR, DC CAPSTAN EG-530KD-2B	6650-09
3-44	5801578200	REEL TABLE H ASSY	5520-95
3-45	5801579500	REEL TABLE HD ASSY	5520-96
3-46	5800539800	WASHER, TEFLON 1. 7X4X0. 3T	
3-47	5801577700	COIL SHAFT ASSY, H	
3-48	*5801577400	REEL SHAFT BASE ASSY	
3-49	*5801576000	BRACKET, REEL	
3-50	*5200363310	SENSOR (R) PCB ASSY	Refer to pages 41 and 45

(Continued on page 45)

MIXER PCB ASSY

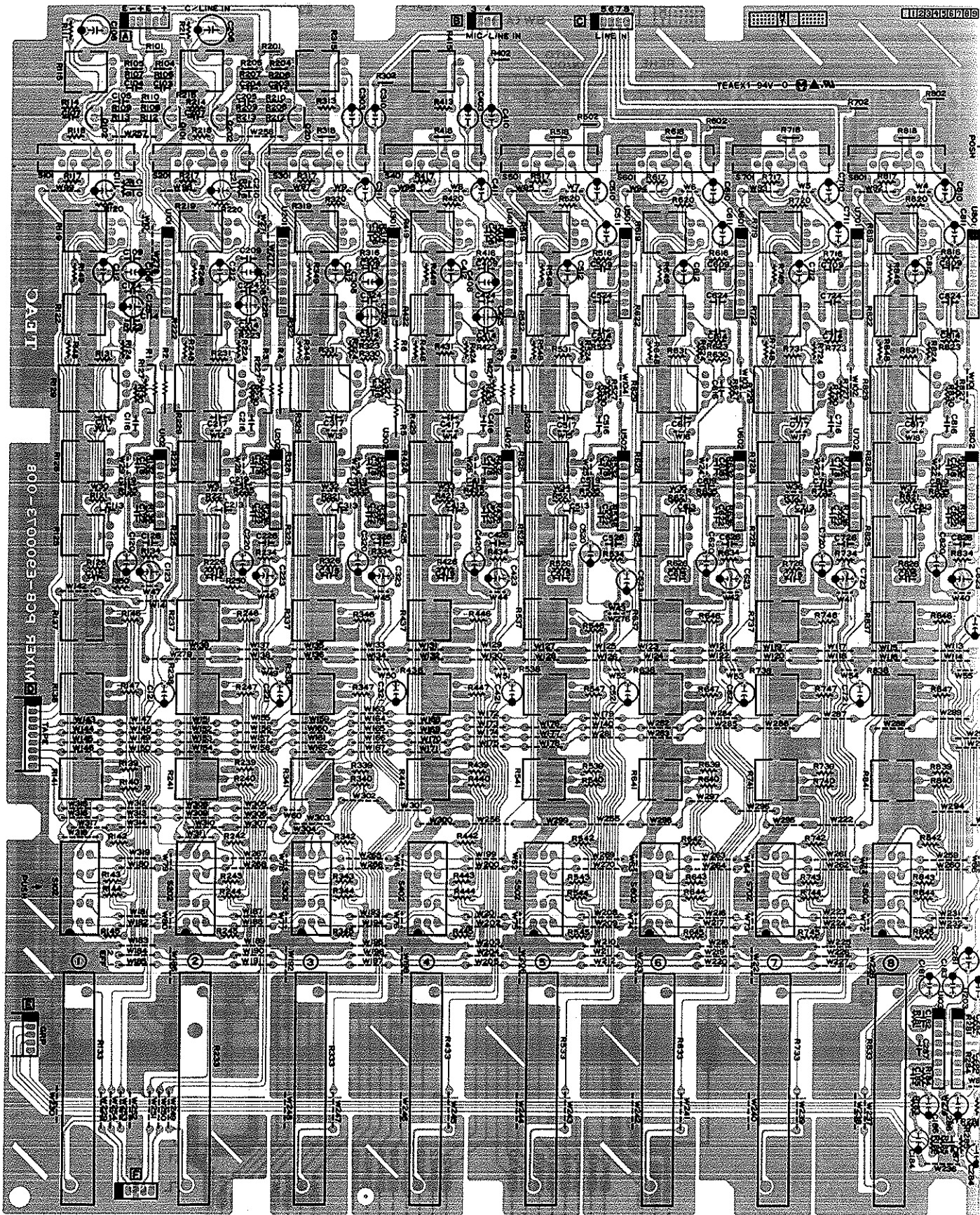

R/P PCB ASSY

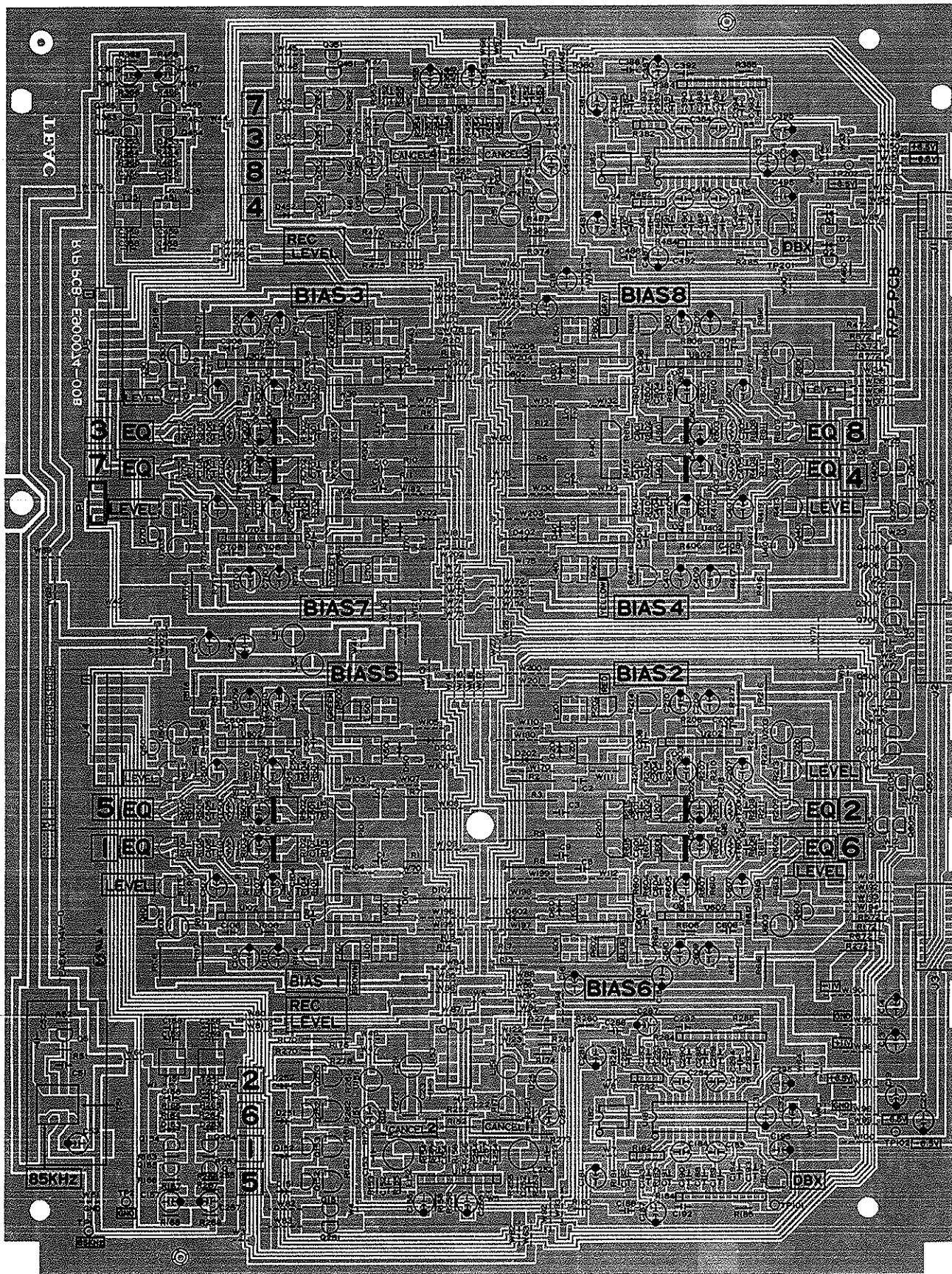

SW A PCB ASSY

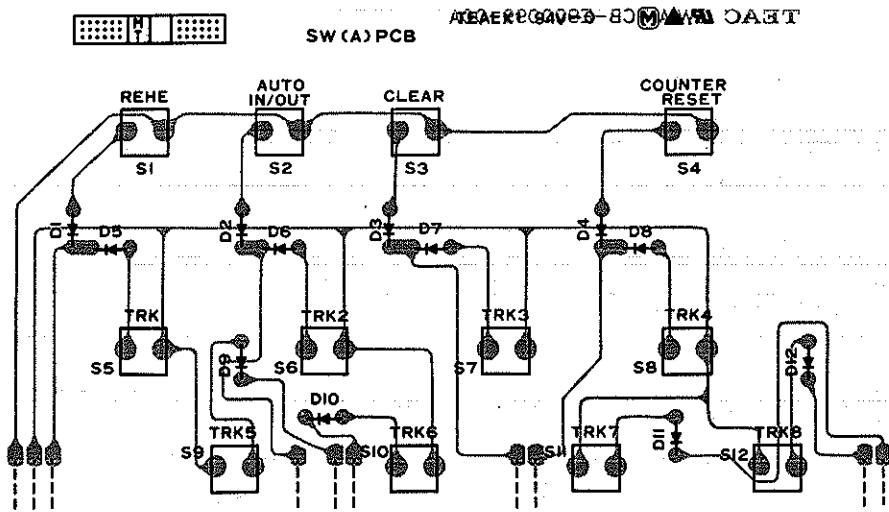

TRANS PCB ASSY

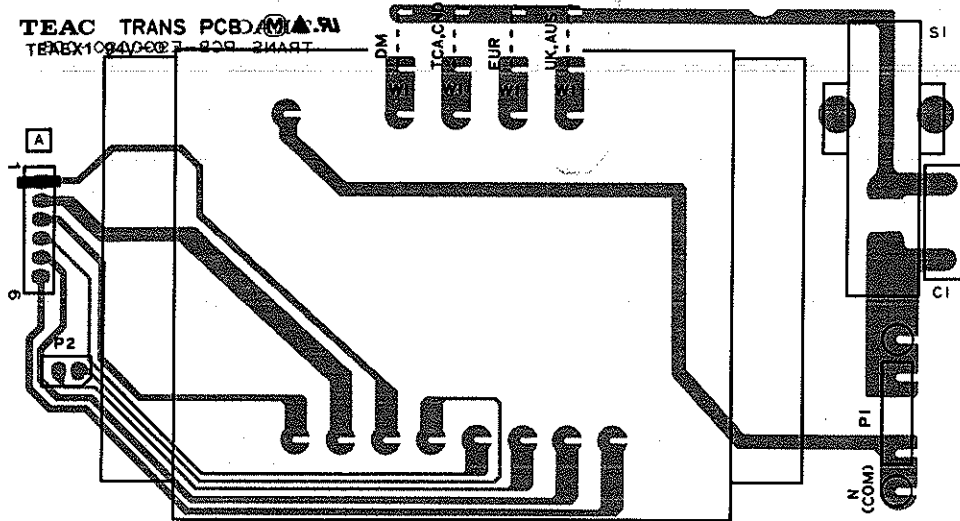

FL PCB ASSY

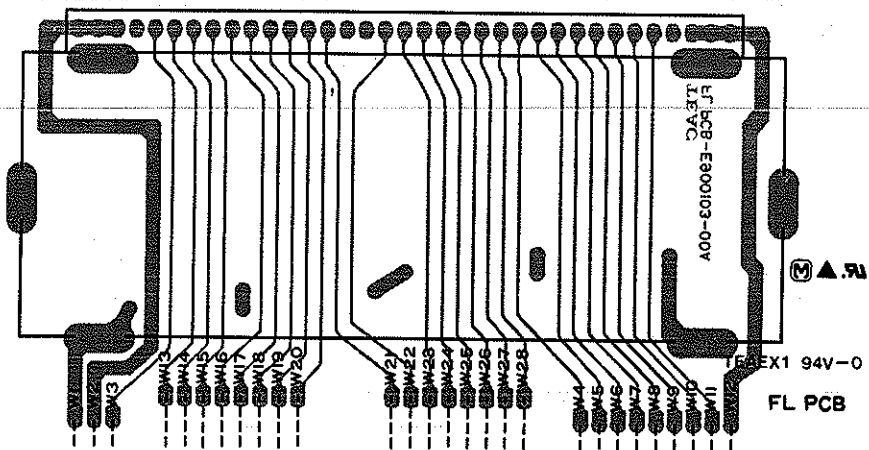

DBX PCB ASSY

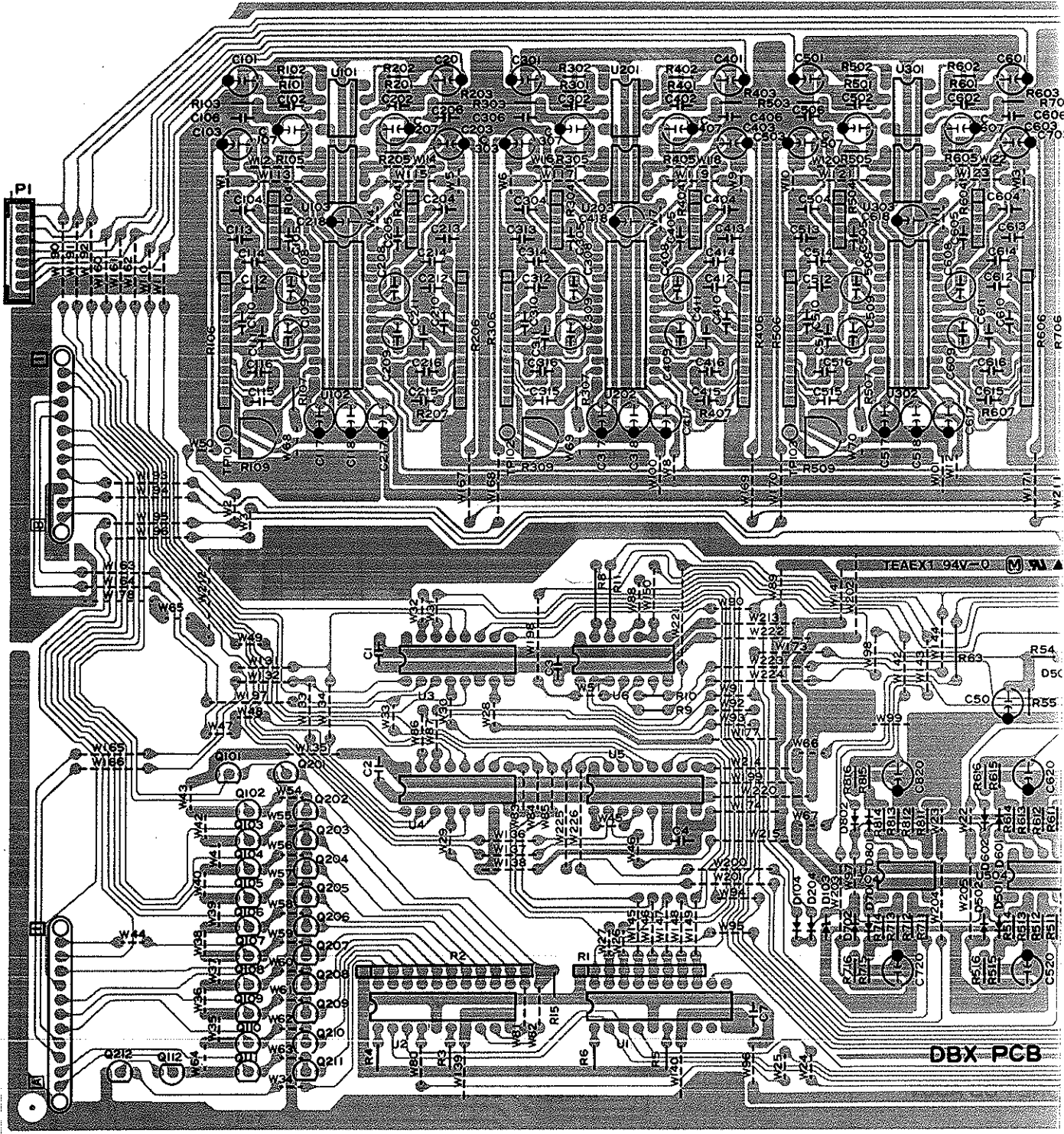

JOINT POWER PCB ASSY

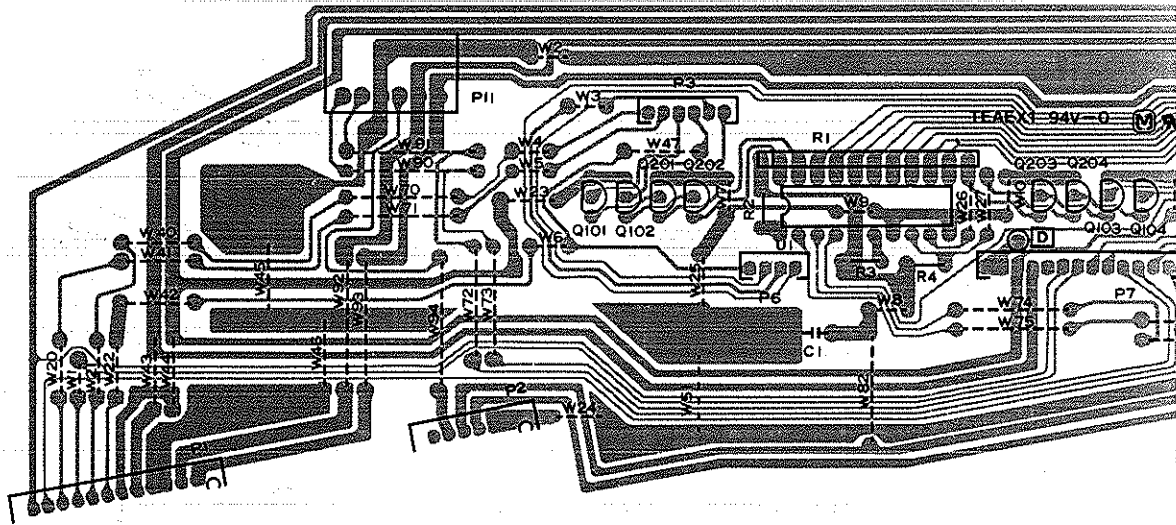

INPUT PCB ASSY

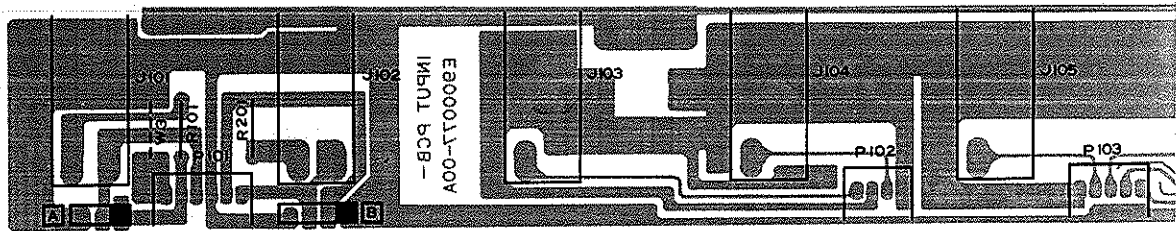

I/O PCB ASSY

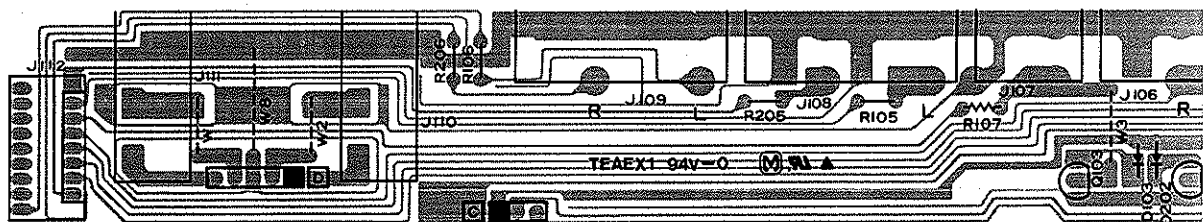

JOINT FL PCB ASSY

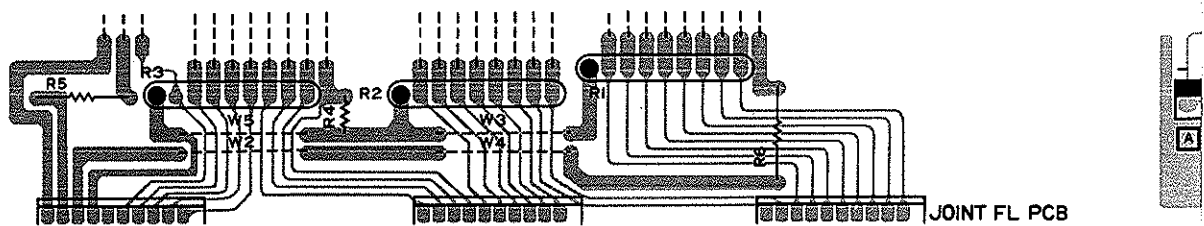

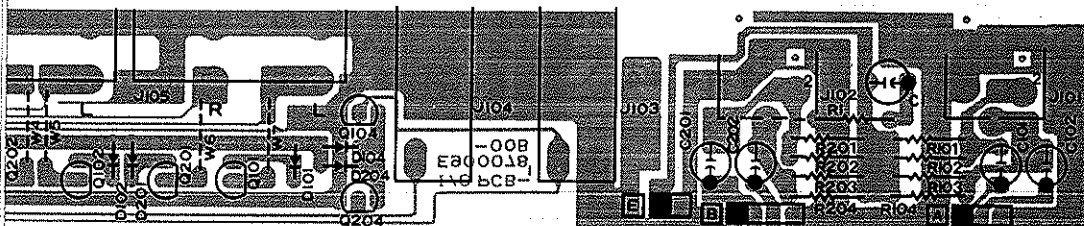
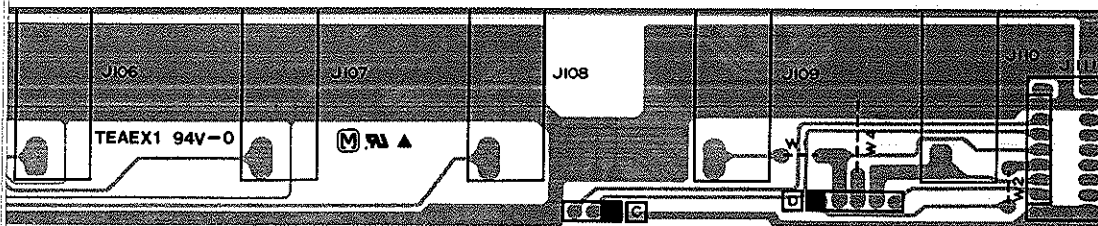
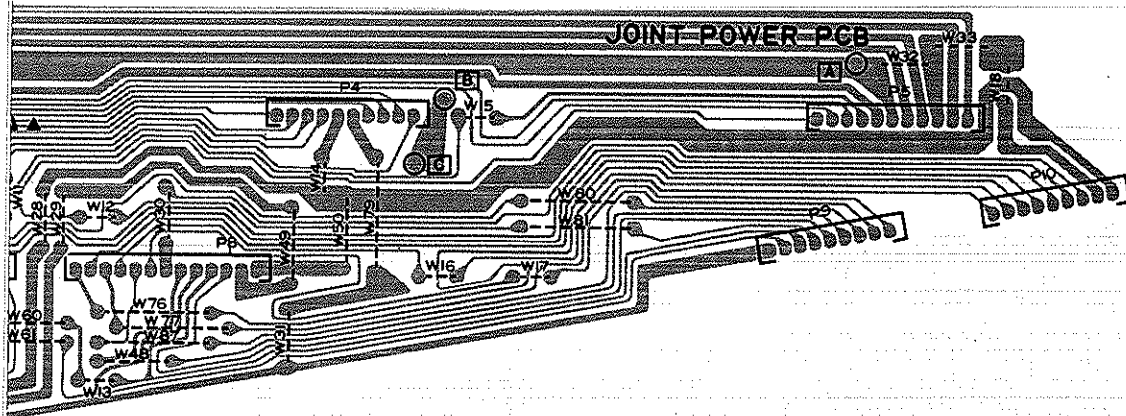

ONE PCB ASSY

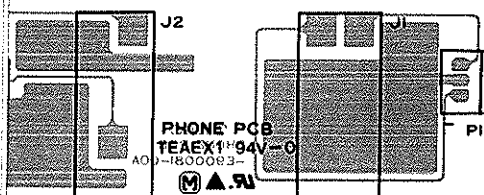

INSERT PCB ASSY

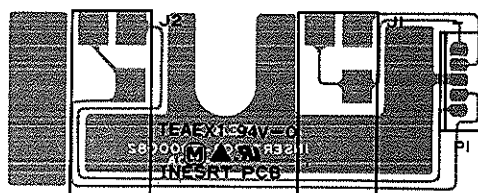

SW (E) PCB ASSY

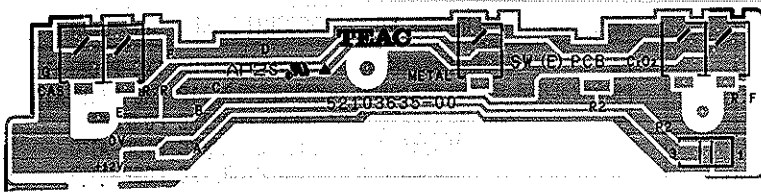

PITCH CONTROL PCB ASSY

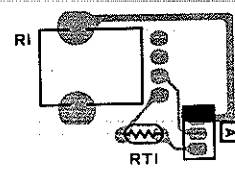

SW B PCB ASSY

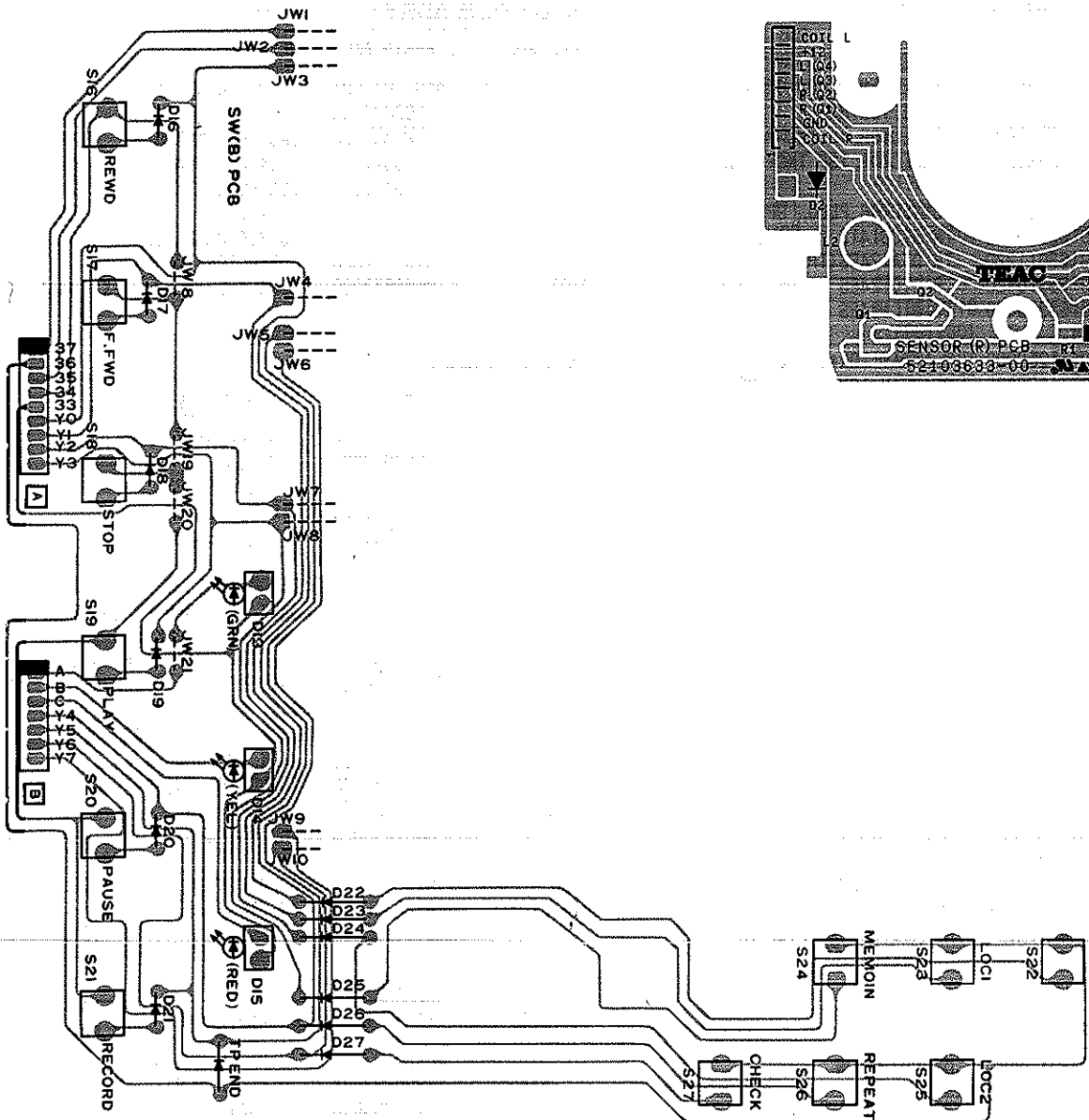

SENSOR (R) PCB ASSY

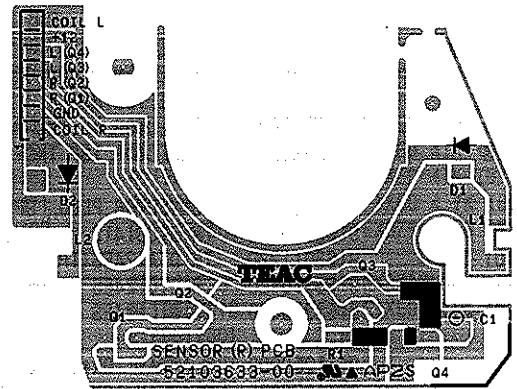

CONTROL PCB ASSY

REF. NO.	PARTS NO.	DESCRIPTION
	*E95010100A	CONTROL PCB ASSY
	*E90010100A	CONTROL PCB
CR1	9173008400	OSC, CERAMIC FCR4. 19MC5
D1-3	9165022150	DIODE, ISS133T
D4	9166045751	DIODE, ZENER RD3. 9ESAB2
D5	9166046451	DIODE, ZEODE, RD7. 5ESAB2
D6	9165020550	DIODE, 1N4003
D7	9166046352	DIODE, ZENER RD6. 8ESAB3
D8-11	9165022150	DIODE, ISS133T
J1, 2	9143427000	CONNECTOR, TXC-P9X-A1
J4-6	9143912000	CONNECTOR, TFC-B10 YE1
P1	9143231000	CONNECTOR PLUG, 3P (WHT)
P2	9143233000	CONNECTOR PLUG, 5P (WHT)
P3	9143232000	CONNECTOR, B4B-PH-K-S
P4	9143232020	CONNECTOR PLUG, 4P (RED)
P5	9143235000	CONNECTOR PLUG, 7P (B7B-PH)
P6	9143230000	CONNECTOR PLUG, 2P (WHT)
P8	9143237000	CONNECTOR PLUG, 9P
P9	9143235000	CONNECTOR PLUG, 7P (B7B-PH)
P10	9143922000	CONNECTOR, 5267-2AXW
Q1-3	9163310420	TR, DTC124ES
Q4, 9	9163011220	TR, DTA124ES (TP)
Q5	9163450400	TR, DT5C124ES
Q6	9163310420	TR, DTC124ES
Q7	9163610400	TR, 2SD1861
Q8	9163014020	TR, 2SD1861
Q10, 11	9163310420	TR, DTC124ES
R5	9112059810	VR, SEMI-FIXED 10K (B)
R11	9112059910	VR, SEMI-FIXED 2. 2K (B)
R55	9112058010	VR, SEMI-FIXED 1K (B)
R65	9111257000	R, ARRAY 10KX4
TP1-4	9160012601	PIN, T. P.
U1	9167026800	IC, UPD78042GF-091-3B9
U2	9167026400	IC, TC74HC138P
U3	9167026500	IC, NJM2904L
U4, 5	9167021100	IC, BA6219
U6, 7	9167028100	IC, BA10393N

TR A PCB ASSY

REF. NO.	PARTS NO.	DESCRIPTION
	*E95010500A	TR A PCB ASSY
	*E90010500A	TR A PCB
Q9	△ 9163610600	TR, 2SD1406Y

TR B PCB ASSY

REF. NO.	PARTS NO.	DESCRIPTION
	*E95010600A	TR B PCB ASSY
	*E90010600A	TR B PCB
Q8	△ 9163203200	TR, 2SB1015Y

TR C PCB ASSY

REF. NO.	PARTS NO.	DESCRIPTION
	*E95010700A	TR C PCB ASSY
	*E90010700A	TR C PCB
Q10	△ 9167026700	IC, NJM7812FA

MIXER PCB ASSY

REF. NO.	PARTS NO.	DESCRIPTION
	*E95007300A	MIXER PCB ASSY
	*E90007300A	MIXER PCB
J1, 2	9143431000	CONNECTOR, 13P TXC-P13X
Q101, 201	9163450220	TR, 2SC1844F
Q102, 202	9163450220	TR, 2SC1844F
R53	9172024600	VR, 10KA*2
R115-415	9172024200	VR, 10K (RD)
R119-819	9172024600	VR, 10KA*2
R122-822	9172024501	VR, 100KB
R125-825	9172024501	VR, 100KB
R128-828	9172024000	VR, 10KB
R129-829	9172024300	VR, 200KC*2
R133-833	9172023800	VR, 10KA RS45
R137-837	9172024400	VR, 10KA
R138-838	9172024400	VR, 10KA
R141-841	9172024000	VR, 10KB
R182, 382	9172023700	VR, 10KA*2
R582-782	9172024400	VR, 10KA
R910, 910	9172024600	VR, 10KA*2
S1, 2	9135035000	PUSH SW, SPEC21HC02-TK
S3	9135035100	PUSH SW, SPEC71HC02-TK
S101-801	9135035200	SLIDE SW, SSSU023NB2-TK
S102-802	9135035000	PUSH SW, SPEC21HC02-TK
U101-801	9167017300	IC, NJM4565LD
U102-802	9167017300	IC, NJM4565LD
U103-703	9167017300	IC, NJM4565LD
U104, 204	9167017300	IC, NJM4565LD
U105	9167022300	IC, LA6515

POWER PCB ASSY

REF. NO.	PARTS NO.	DESCRIPTION
	*E95007500A	POWER PCB ASSY
	*E90007500A	POWER PCB
	9260069801	HEAT SINK, SD385
	9783213008	SCREW, BTT-B M3*8
	5332015800	FUSE HOLDER [E, UK, A]
C16, 17	△ 9117184020	C, ELEC 47UF 25V
C20, 21	△ 9117303600	C, ELEC 4700UF 25V
C30	△ 9117302800	C, ELEC 3300UF 25V
C32	△ 9117303800	C, ELEC 330UF 100V
C34	△ 9117303700	C, ELEC 470UF 100V
D1, 2	△ 9165020550	DIODE, 1N4003
D3	9165022150	DIODE, ISS133T
D4, 5	△ 9165022150	DIODE, ISS133T
D6, 7	9166046351	DIODE, ZENER RD6. 8ESAB2
D8	△ 9165022800	DIODE, PBPC303

POWER PCB ASSY

REF. NO.	PARTS NO.	DESCRIPTION
D9, 10	△ 9165022200	D10DE, PR3003
D11	9166037951	D10DE, ZENER RD33ESAB2
D12, 14	△ 9165020550	D10DE, 1N4003
D13	△ 9166046051	D10DE, ZENER RD5.1ES B2
F1, 2	△ 5142189000	FUSE, MINI 2A 250V [E, UK, A]
J1	9143889000	CONNECTOR, TKC-M06XA1
J2	9143892000	CONNECTOR, TKC-M12XA1
J3	9143387000	JACK, 2P. YKC21-3063 BLK
P1, 2	9143926000	CONNECTOR, 5267-6AXW
P3	9143170000	CONNECTOR PLUG, 2P
Q1, 7	9163009920	TR, 2SA1015GR
Q2-4	9163310420	TR, DTC124ES
Q5	△ 9163610000	TR, 2SD1506Q
Q6	△ 9163203100	TR, 2SB1065Q
R17	△ 9113056050	R, CARBON R-16 JFT 220
R18	△ 9113066050	R, CARBON R-16 JFT 560
R35	△ 9113052050	R, CARBON R-16 JFT 150
R37	△ 9114404060	R, METAL OXIDE 2W 22 FH-10
S1-3	9135035300	SW, SLIDE SSU122NB2
U1	△ 9167014800	IC, NJM7805FA
U2	△ 9167022400	IC, M5230LA
U3	9167017300	IC, NJM4565LD
U4	△ 9167026000	IC, M5231TL

R/P PCB ASSY

REF. NO.	PARTS NO.	DESCRIPTION
	*E95007400A	R/P PCB ASSY
	*E90007400A	R/P PCB
	9260208700	SHIELD CASE
D1, 2	9165022150	D10DE, ISS133T
D101-801	9165022150	D10DE, ISS133T
D102-802	9165022150	D10DE, ISS133T
D151-451	9165022150	D10DE, ISS133T
D152-452	9165022150	D10DE, ISS133T
J1	9143424000	CONNECTOR, 6P TXC-P6X
J2	9143428000	CONNECTOR, 10P TXC-P10X-A1
J3	9143429000	CONNECTOR, 11P TXC-P11X-A1
J4, 5	9143259000	CONNECTOR PLUG, 11P
K101-801	9138001600	RELAY, AHX203
L51, 52	9173008500	COIL, 1.2MH
L101-801	9173009500	COIL, SERIES 20D6(H=9.7)
L151-451	9173008600	COIL, 8.2MH
L152-452	9173008700	COIL, 36MH
P1	9143233000	CONNECTOR PLUG, 5P (WHT)
P101	9143926000	CONNECTOR, 5267-6AXW
P102, 502	9143922000	CONNECTOR, 5267-2AXW
P201	9143926020	CONNECTOR, 5267-6AXR
P202, 602	9143922020	CONNECTOR, 5267-2AXR
P301	9143926010	CONNECTOR, 5267-6AXB
P302, 702	9143922010	CONNECTOR, 5267-2AXB
P401	9143926040	CONNECTOR, 5267-6AXY

R/P PCB ASSY

REF. NO.	PARTS NO.	DESCRIPTION
P402, 802	9143922040	CONNECTOR, 5267-2AXY
Q1	9164004720	FET, 2SJ-40(D) TP
Q2	9164004620	FET, 2SK381D
Q51	9166450520	TR, 2SC2603F
Q101-801	9163450020	TR, DTC314TS
Q105, 805	9163011220	TR, DTA124ES(TP)
Q106-806	9163310420	TR, DTC124ES
Q151-451	9163450020	TR, DTC314TS
Q153-453	9163450020	TR, DTC314TS
Q153-453	9165022150	D10DE, ISS133T
Q154-454	9163450320	TR, 2SC2002L
Q155-455	9163310620	TR, 2SC2878A
RT101-801	9114412000	THERMISTOR, ERTD2FHL333S
R109-809	9112056010	VR, SEMI-FIXED 4.7K (B)
R113-813	9112056010	VR, SEMI-FIXED 4.7K (B)
R114-814	9112059410	VR, SEMI-FIXED 100K (B)
R161-461	9112059710	VR, SEMI-FIXED 47K (B)
R162-462	9112059710	VR, SEMI-FIXED 47K (B)
R171-471	9112056010	VR, SEMI-FIXED 4.7K (B)
R182-482	9111255000	R, ARRAY EXBZ5L045G DBX
R184-484	9111256000	R, ARRAY EXBZ13L046G DBX
R187, 387	9112056010	VR, SEMI-FIXED 4.7K (B)
TP1, 2	9160012601	PIN, T. P
TP101, 201	9160012601	PIN, T. P
T51	9173008800	COIL, OSC 85KHZ
T151-451	9173008900	COIL, SLAVE 85KHZ
U101-801	9173009300	COIL, TRAP 85KHZ
U102-802	9167015910	IC, NJM2068SD
U103-803	9173009400	COIL, L. P. F 85KHZ
U151-451	9173009400	COIL, L. P. F 85KHZ
U152, 352	9167014010	IC, UPC4570HA
U153, 353	9167009800	IC, TC4066BP
U181, 381	9167026100	IC, AN7367K
U182, 382	9167015000	IC, M5218AP

SW A PCB ASSY

REF. NO.	PARTS NO.	DESCRIPTION
	*E95009900A	SW A PCB ASSY
	*E90009900A	SW A PCB
D1-12	9165022150	D10DE, ISS133T
S1-12	9136001820	SW, TACT SKHVB3520-TK

TRANS PCB ASSY

REF. NO.	PARTS NO.	DESCRIPTION
	*E95008000A	TRANS PCB ASSY
	*E90008000A	TRANS PCB
	5730007500	COVER, CAPACITOR[E, UK, A]
	5327007200	TERMINAL, LAPPING 2P[UK, A]
C1	△ 9120000100	C, SPARK KILLER 0.0047UF/400V
P2	9143922000	CONNECTOR, 5267-2AXW
S1	△ 9135035400	SW, POWER PS-2BP1-T3

FL PCB ASSY

REF. NO.	PARTS NO.	DESCRIPTION
	*E95010300A	FL PCB ASSY
	*E90010300A	FL PCB
	9260164600	FL HOLDER
FL	9174016300	FL DISPLAY, FL-BJ286-GK

DBX PCB ASSY

REF. NO.	PARTS NO.	DESCRIPTION
	*E95008400A	DBX PCB ASSY
	*E90008400A	DBX PCB
	9143880000	WIRE HOLDER, 11P
D50, 51	9165022150	DIODE, ISS133T
D101-801	9165022150	DIODE, ISS133T
D102-802	9165022150	DIODE, ISS133T
D103	9166045551	DIODE, ZENER, RD3. 3ESAB2
D104, 204	9165022150	DIODE, ISS133T
J1	9143422000	CONNECTOR, 4P TXC-P4X
J2, 3	9143431000	CONNECTOR, 13P TXC-P13X
P1	9143237000	CONNECTOR PLUG, 9P
Q50	9163450020	TR, DTC314TS
Q101-112	9163011220	TR, DTA124ES (TP)
Q117	9163310420	TR, DTC124ES
Q201-212	9163310420	TR, DTC124ES
R1	9111250000	R, ARRAY 10K*8
R2	9111258000	R, ARRAY 10K*11
R104-804	9111255000	R, ARRAY EXBZ5L045G DBX
R106-806	9111256000	R, ARRAY EXBZ13L046G DBX
R109, 309	9112056010	VR, SEMI-FIXED 4.7K (B)
R509, 709	9112056010	VR, SEMI-FIXED 4.7K (B)
U1, 2	9167026200	IC, M66006P
U3-5	9167020600	IC, TC4053BP
U6	9167009800	IC, TC4066BP
U50	9167017300	IC, NJM4565LD
U101-401	9167025900	IC, NJM4565DD
U102-402	9167026100	IC, AN7367K
U103-403	9167025900	IC, NJM4565DD
U104-404	9167008100	IC, NJM4558D

JOINT MIXER PCB ASSY

REF. NO.	PARTS NO.	DESCRIPTION
	*E95008500A	JOINT MIXER PCB ASSY
	*E90008500A	JOINT MIXER PCB
P101, 102	9143451000	CONNECTOR, TXC-P13P-A1
P103, 104	9143447000	CONNECTOR, TXC-P09P-A1

JOINT POWER PCB ASSY

REF. NO.	PARTS NO.	DESCRIPTION
	*E95007600A	JOINT POWER PCB ASSY
	*E90007600A	JOINT POWER PCB
P1	9143884000	CONNECTOR, TXC-M12P-B1
P2	9143881000	CONNECTOR, TXC-M06P-B1
P3	9143444000	CONNECTOR, TXC-P06P-A1

JOINT POWER PCB ASSY

REF. NO.	PARTS NO.	DESCRIPTION
P4	9143448000	CONNECTOR, 10P TXC-P10P-A1
P5	9143449000	CONNECTOR, 11P TXC-P11P-A1
P6	9143442000	CONNECTOR, TXC-P04P-A1
P7, 8	9143451000	CONNECTOR, TXC-P13P-A1
P9, 10	9143447000	CONNECTOR, TXC-P09P-A1
P11	9143942000	CONNECTOR, 5268-6AXW
Q101-104	9163011220	TR, DTA124ES (TP)
Q201, 204	9163310420	TR, DTC124ES
R1	9111258000	R, ARRAY 10K*11
U1	9167026200	IC, M66006P

INPUT PCB ASSY

REF. NO.	PARTS NO.	DESCRIPTION
	*E95007700A	INPUT PCB ASSY
	*E90007700A	INPUT PCB
J101, 102	9143491000	JACK, CPJ-064 6.3
J103-110	9143917000	JACK, CPJ-064-3
J111	9143427000	CONNECTOR, TXC-P9X-A1
P101	9143274000	CONNECTOR PLUG, 6P
P102	9143272000	CONNECTOR, 4P S4B-PH-K
P103	9143273000	CONN. 5P (S05B-PK-K) CD301

I/O PCB ASSY

REF. NO.	PARTS NO.	DESCRIPTION
	*E95007800A	I/O PCB ASSY
	*E90007800A	I/O PCB
D101, 201	9165022150	DIODE, ISS133T
D102, 202	9165022150	DIODE, ISS133T
D103	9165022150	DIODE, ISS133T
D104, 204	9165022150	DIODE, ISS133T
J101, 102	9143382000	JACK, NC3FPR-H-0 (XLR TYPE)
J103, 104	9143916000	JACK, 064-2 BLK
J105, 106	9143387000	JACK, 2P YKC21-3063 BLK
J107	9143920100	JACK, 1P E
J108, 109	9143387000	JACK, 2P YKC21-3063 BLK
J110, 111	9143917000	JACK, CPJ-064-3
J112	9143427000	CONNECTOR, TXC-P9X-A1
Q101, 201	9163450020	TR, DTC314TS
Q102, 202	9163450020	TR, DTC314TS
Q103	9163450020	TR, DTC314TS
Q104, 204	9163450020	TR, DTC314TS

JOINT FL PCB ASSY

REF. NO.	PARTS NO.	DESCRIPTION
	*E95010200A	JOINT FL PCB ASSY
	*E90010200A	JOINT FL PCB
R1-3	9111259000	R, ARRAY 22K*8

PHONE PCB ASSY

REF. NO.	PARTS NO.	DESCRIPTION
	*E95008100A	PHONE PCB ASSY
	*E90008100A	PHONE PCB
	9260205900	MNT PLATE
	9260205801	BRACKET, PH
J1	9143919000	JACK, 0642RD RED
J2	9143916000	JACK, 064-2 BLK
P1	9143231000	CONNECTOR PLUG, 3P (WHT)

INSERT PCB ASSY

REF. NO.	PARTS NO.	DESCRIPTION
	*E95008200A	INSERT PCB ASSY
	*E90008200A	INSERT PCB
	9260205900	MNT PLATE
	9260205801	BRACKET, PH
J1, 2	9143918000	JACK, 064-4B BLK
P1	9143233000	CONNECTOR PLUG, 5P (WHT)

SW (E) PCB ASSY

REF. NO.	PARTS NO.	DESCRIPTION
	*5200363520	SW (E) PCB ASSY
	*5210363500	SW (E) PCB
S1, 2	5301754500	SWITCH, LEAF MTS10161MVL0

PITCH CONTROL PCB ASSY

REF. NO.	PARTS NO.	DESCRIPTION
	*E95010400A	PITCH CONTROL PCB ASSY
	*E90010400A	PITCH CONTROL PCB
RT1	9114413000	THERMISTOR, ERT02FFL400S
R1	9172024100	VR, SLIDE RK11K 1.5K

SW B PCB ASSY

REF. NO.	PARTS NO.	DESCRIPTION
	*E95010000A	SW B PCB ASSY
	*E90010000A	SW B PCB
	M00070300A	SPACER, LED LH-3
D13	9174016400	LED, SLR-37 GRN
D14	9174016500	LED, SLR-37 ORG
D15	9174016600	LED, SLR-37 LED
D16-27	9165022150	D10DE, ISS133T
S16-27	9136001820	SW, TACT SKHVBE3520-TK

SENSOR (R) PCB ASSY

REF. NO.	PARTS NO.	DESCRIPTION
	*5200363310	SENSOR (R) PCB ASSY
	*5210363300	SENSOR (R) PCB
D1	5224017120	D10DE, 1SR139-200 T-31
Q1~4	5228017200	PHOTO-REFL, NJL5161KF1-B

EXPLODED VIEW -3 (Continued from page 31)

REF. NO.	PARTS NO.	DESCRIPTION	REMARKS
3-51	5801473002	DRIVING PULLEY ASSY	
3-52	5801474500	GEAR, REEL MOTOR	
3-53	5801494600	SPRING, THRUST	
3-54	5370002502	REEL MOTOR ASSY	6620-52
3-55	*5800235900	PLATE, SHIELD	
3-56	*5801204700	SHIELD PLATE(A), MOTOR	
3-61	*5783002605	SCREW, S-TITE PAN M2. 6X5	
3-62	*5783032606	SCREW, S-TITE BIND M2. 6X6	
3-63	*5783032004	SCREW, S-TITE BIND M2X4	
3-64	*5786002000	E-RING, E-2	
3-65	*5730029400	SCREW, PWA2*8FNI	
3-66	*5781952000	NUT, NYLON M2	
3-67	*5785313000	WASHER, POLIS. 3X6X0. 5T	
3-68	*5781112004	SCREW, BIND TAP M2X4	
3-69	*5783032605	SCREW, S-TITE BIND M2. 6X5	
3-70	*5780003003	SCREW, BIND M3X3	
3-71	*5780002004	SCREW, BIND M2X4	
3-72	*5785331500	WASHER, POLYS. 1. 5X4X0. 5T	
3-73	*5730033100	SCREW, SHOULDER M2. 6X5-2	
3-74	*5785331200	WASHER, POLY. 1. 2X3. 0X0. 5T	
3-75	*5780002603	SCREW, BIND M2. 6X3	

7. BLOCK DIAGRAM

ブロック・ダイアグラム

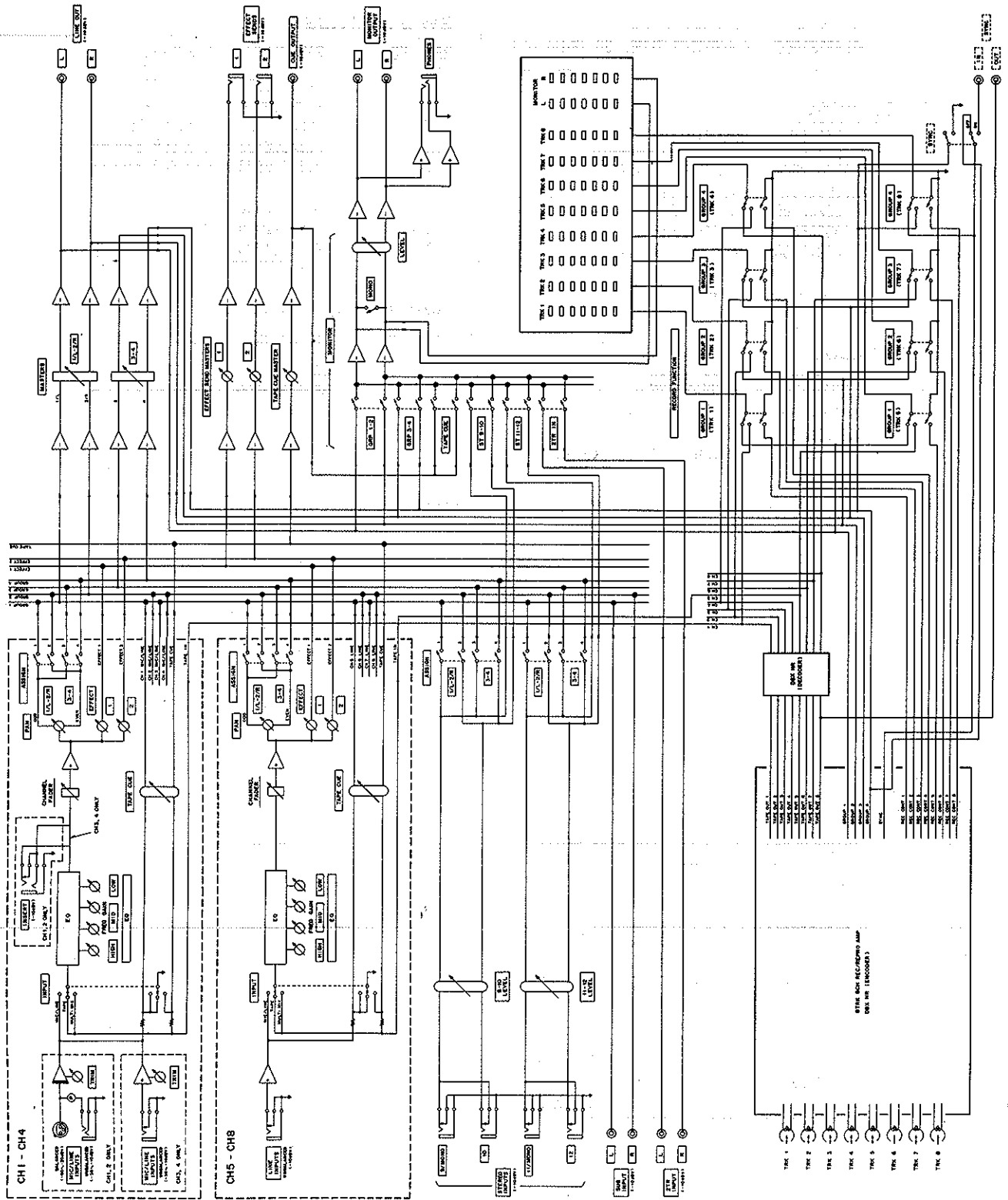
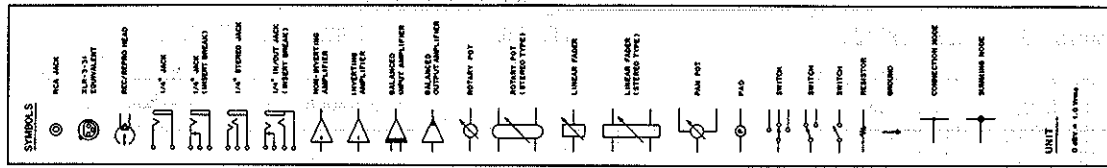

8. LEVEL DIAGRAMS

レベル・ダイアグラム

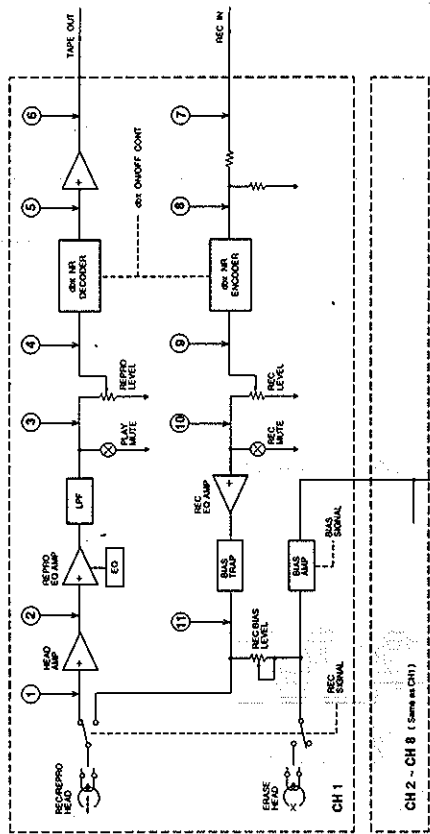

CH2 ~ CH 8 (Same as CH1)

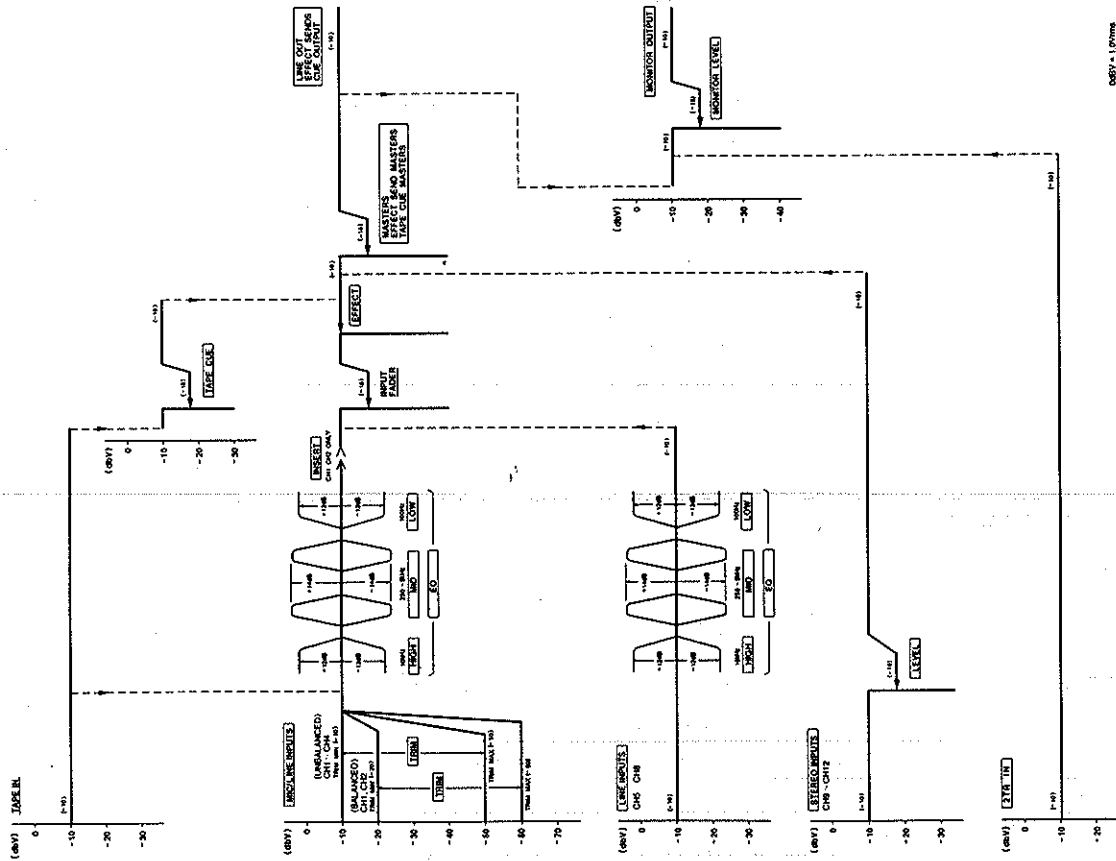
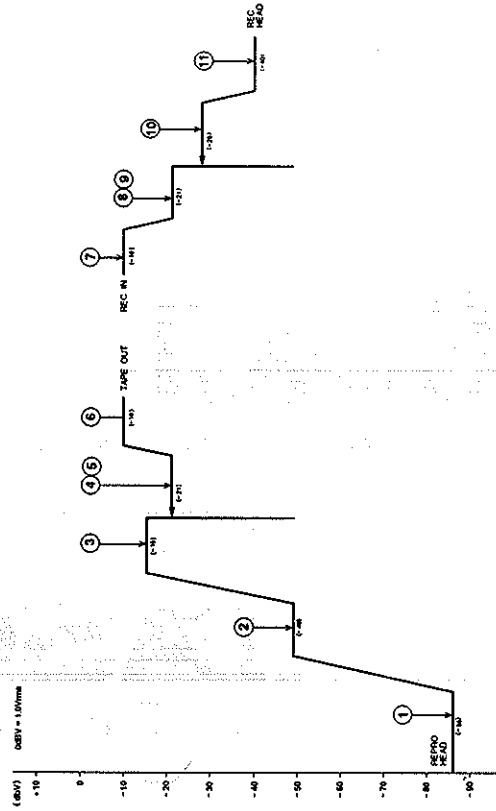

488MKII

TASCAM TEAC Professional Division

ティアック株式会社

営業部 ☎ (0422) 52-5072 〒180 東京都武蔵野市中町 3-7-3

技術的なお問合わせ	AV技術相談室	☎ (0425) 60-7761	〒208 東京都武蔵村山市伊奈平 2-11-1
サービスに関するお問合わせは、最寄りの営業所等へご連絡ください。営業所にはサービス・センターが併設されています。	札幌営業所	☎ (011) 521-4101(代)	〒064 札幌市中央区南7条西 2-2
	仙台営業所	☎ (022) 227-1501(代)	〒980 仙台市青葉区1番町 2-5-5
	新潟サービス	☎ (025) 245-0103	〒950 新潟県新潟市本馬越 1-4-11
	大宮サービス	☎ (048) 642-4551(代)	〒330 大宮市三橋 2-8-4 6
	多摩サービス	☎ (0425) 60-8918	〒208 東京都武蔵村山市伊奈平 2-11-1
	千代田東京営業所	☎ (03) 3592-2051(代)	〒100 東京都千代田区永田町 2-10-7
	千葉サービス	☎ (043) 255-1281	〒260 千葉市中央区権森 1-21-13
	神奈川サービス	☎ (0427) 46-6850	〒228 相模原市上鶴間 3 5 5 3 - 1
	静岡サービス	☎ (054) 238-2431	〒422 静岡市高松 1-12-1
	名古屋営業所	☎ (052) 702-3100(代)	〒465 名古屋市名東区上社 5-406
	京都サービス	☎ (075) 871-8730(代)	〒616 京都市右京区常盤窪 1 9
	大阪営業所	☎ (06) 384-5201(代)	〒564 吹田市垂水町 3-3-4-10
	岡山サービス	☎ (0862) 25-8601	〒700 岡山市新保 1 1 4 2 - 6
	広島営業所	☎ (082) 294-4751(代)	〒730 広島市中区西川口 1 3 - 1 9
	福岡営業所	☎ (092) 431-5781(代)	〒812 福岡市博多区東光 2-2-24
	福岡サービス	☎ (092) 936-5672	〒811-2 福岡県粕屋郡志免町志免 1 0 4 1
	サービス1課	☎ (0425) 60-8918	〒208 東京都武蔵村山市伊奈平 2-11-1
			くぼたビル
			中央ビル
			黒井ハイツ
			星ガ岡会館
			清水ビル
			グリーンシティビル
			寿通ハイツ105号
			西垣ビル

TEAC CORPORATION	3-7-3, Nakacho, Musashino-shi, Tokyo 180, Japan	Phone:(0422)52-5081
TEAC AMERICA, INC.	7733 Telegraph Road, Montebello, California 90640	Phone:(213)726-0303
TEAC CANADA LTD.	340 Brunel Road, Mississauga, Ontario L4Z 2C2, Canada	Phone:905-890-8008
TEAC UK LIMITED	5 Marlin House, Marlin's Meadow, The Croxley Centre, Watford, Herts. WD1 8YA, U.K.	Phone:0923-819831
TEAC DEUTSCHLAND GmbH	Bahnstrasse 12, 65205 Wiesbaden-Erbenheim, Germany	Phone:0811-71580
TEAC FRANCE S.A.	17, Rue Alexis-de-Tocqueville, CE 005 92182 Antony Cedex, France	Phone:(1)42.37.01.02
TEAC NEDERLAND BV	Perkinsbaan 11, 3439 ND Nieuwegein, Nederland	Phone:03-402-30229
TEAC AUSTRALIA PTY., LTD. A.C.N. 005 408 462	106 Bay Street, Port Melbourne, Victoria 3207, Australia	Phone:(03)846-1733
TEAC ITALIANA S.p.A.	Via C. Cantù 5, 20092 Cinisello Balsamo, Milano, Italy	Phone:02-66010500

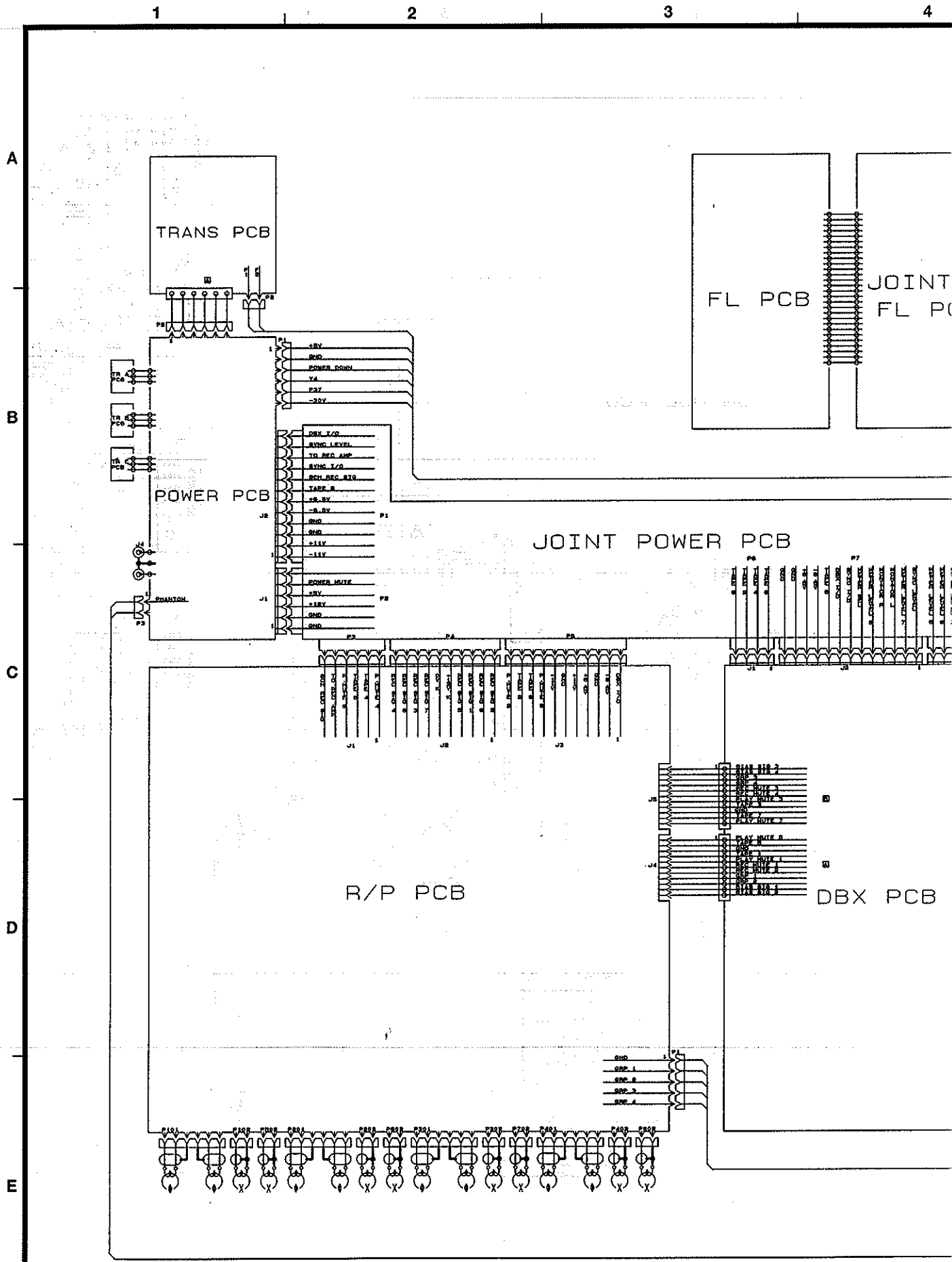

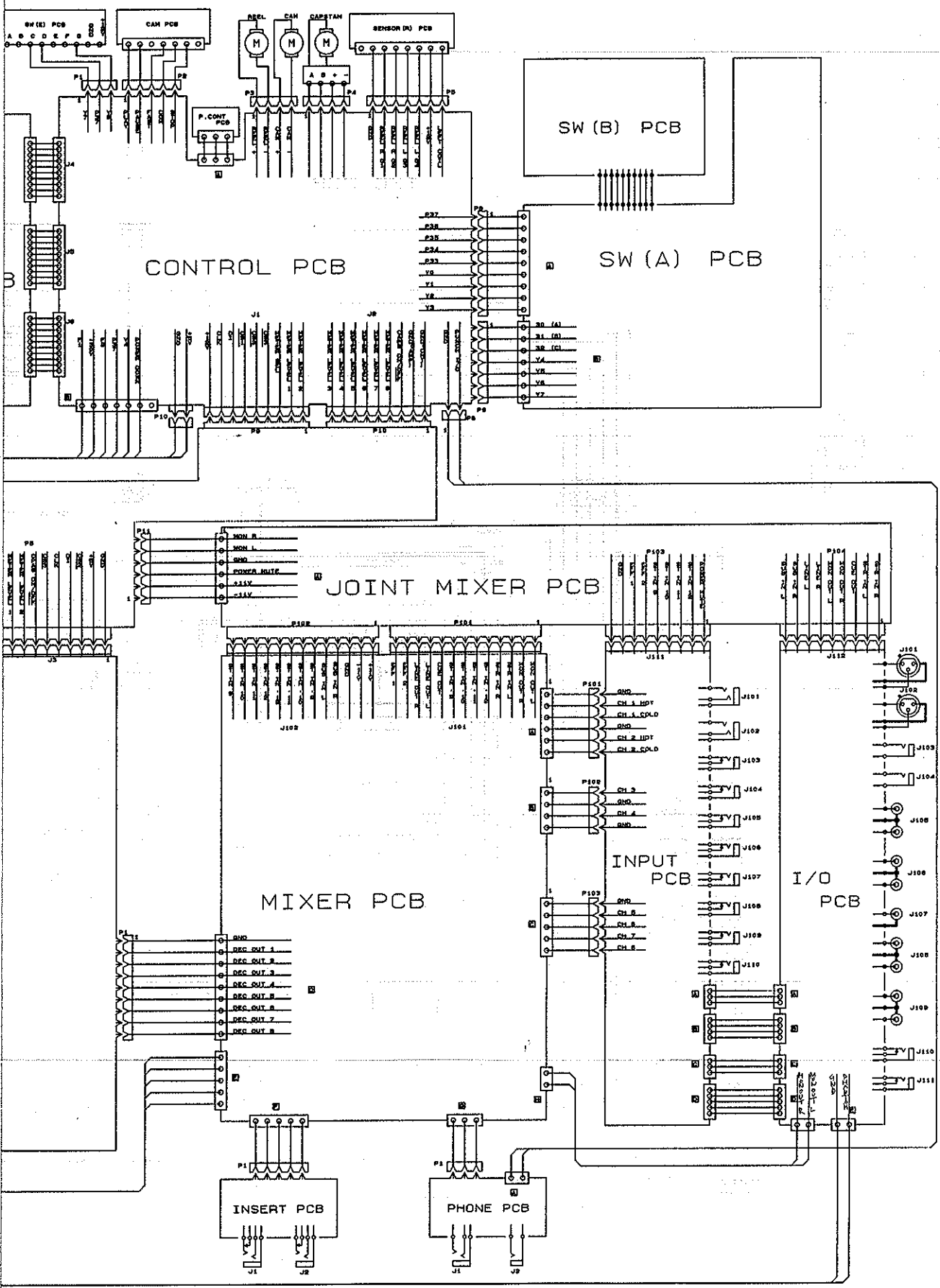

PORTASTUDIO 488MKII <II>

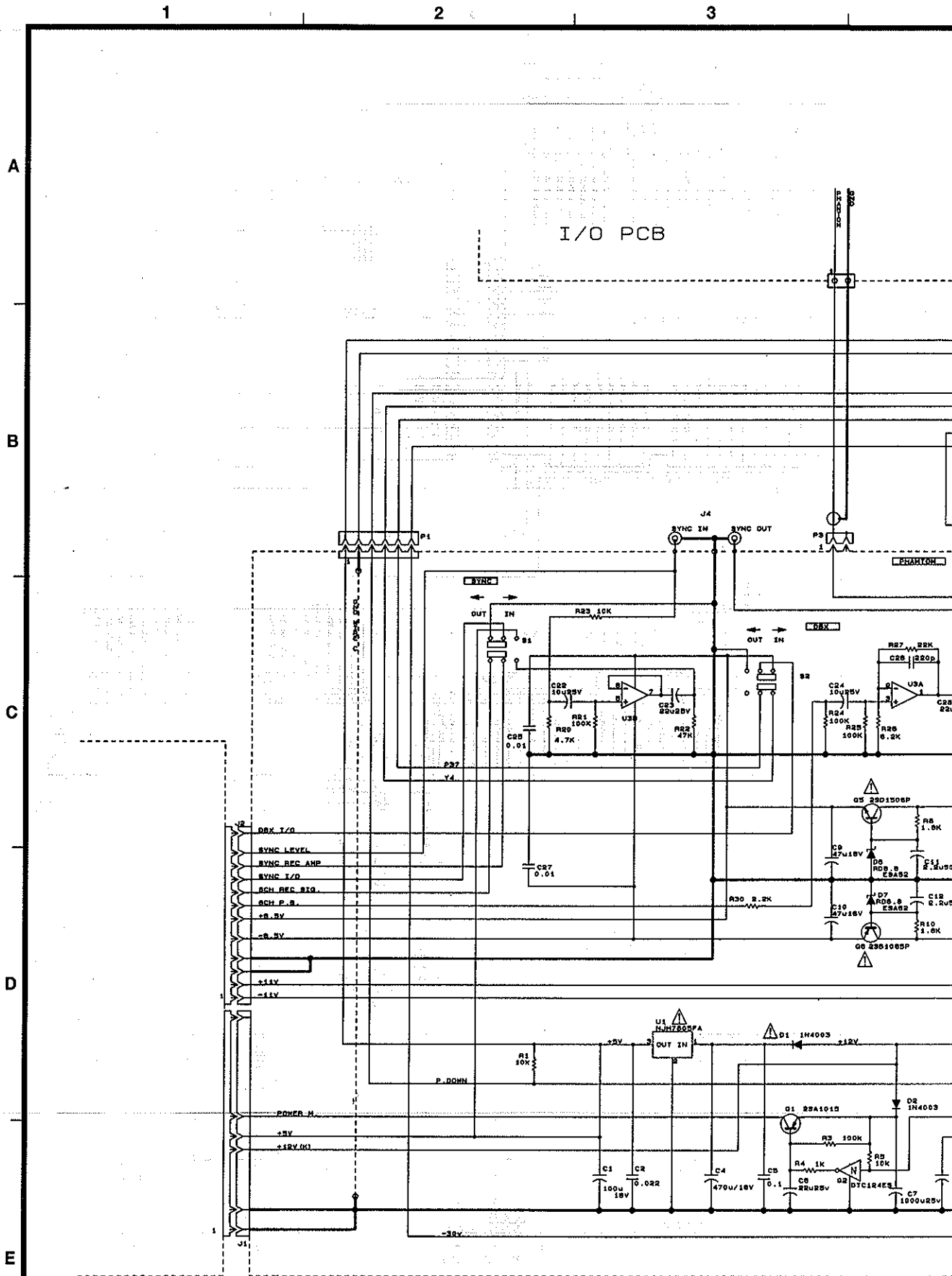

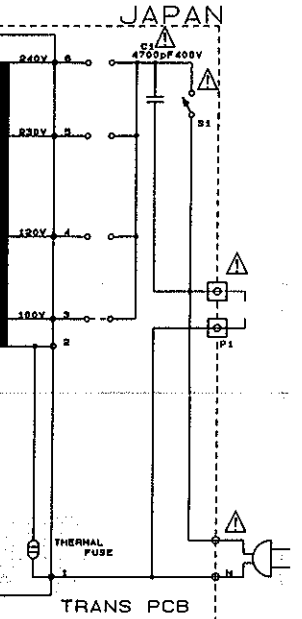
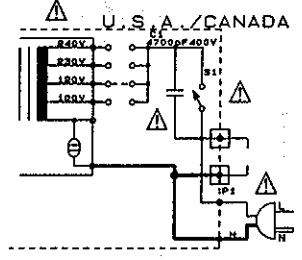
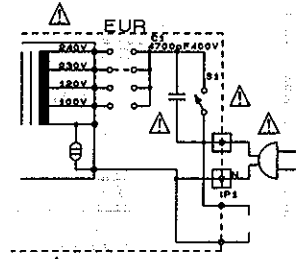
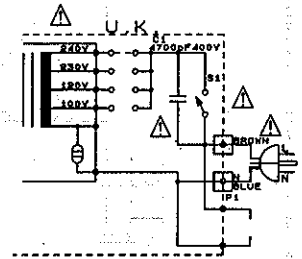
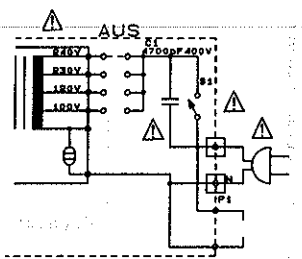
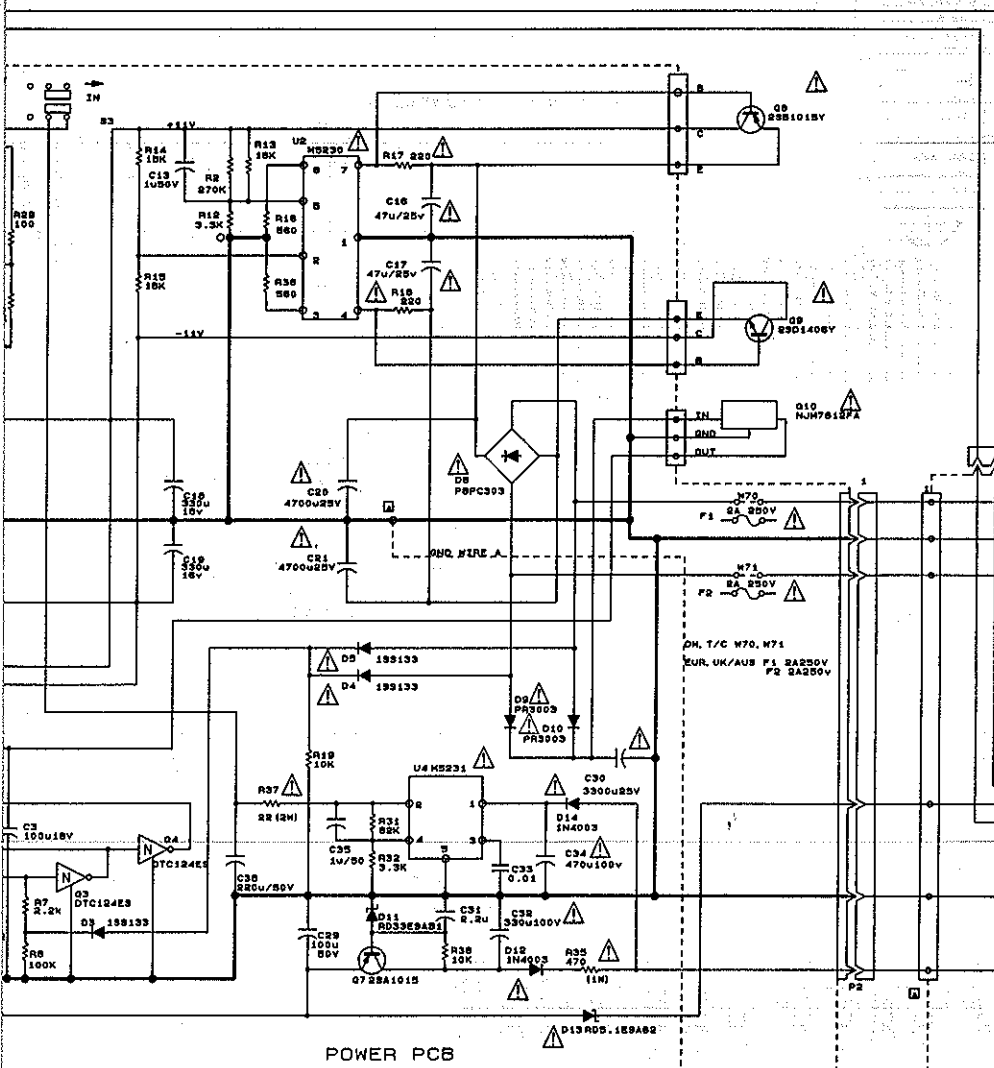
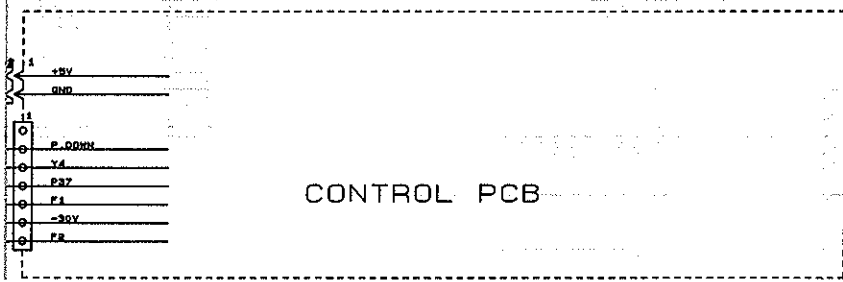

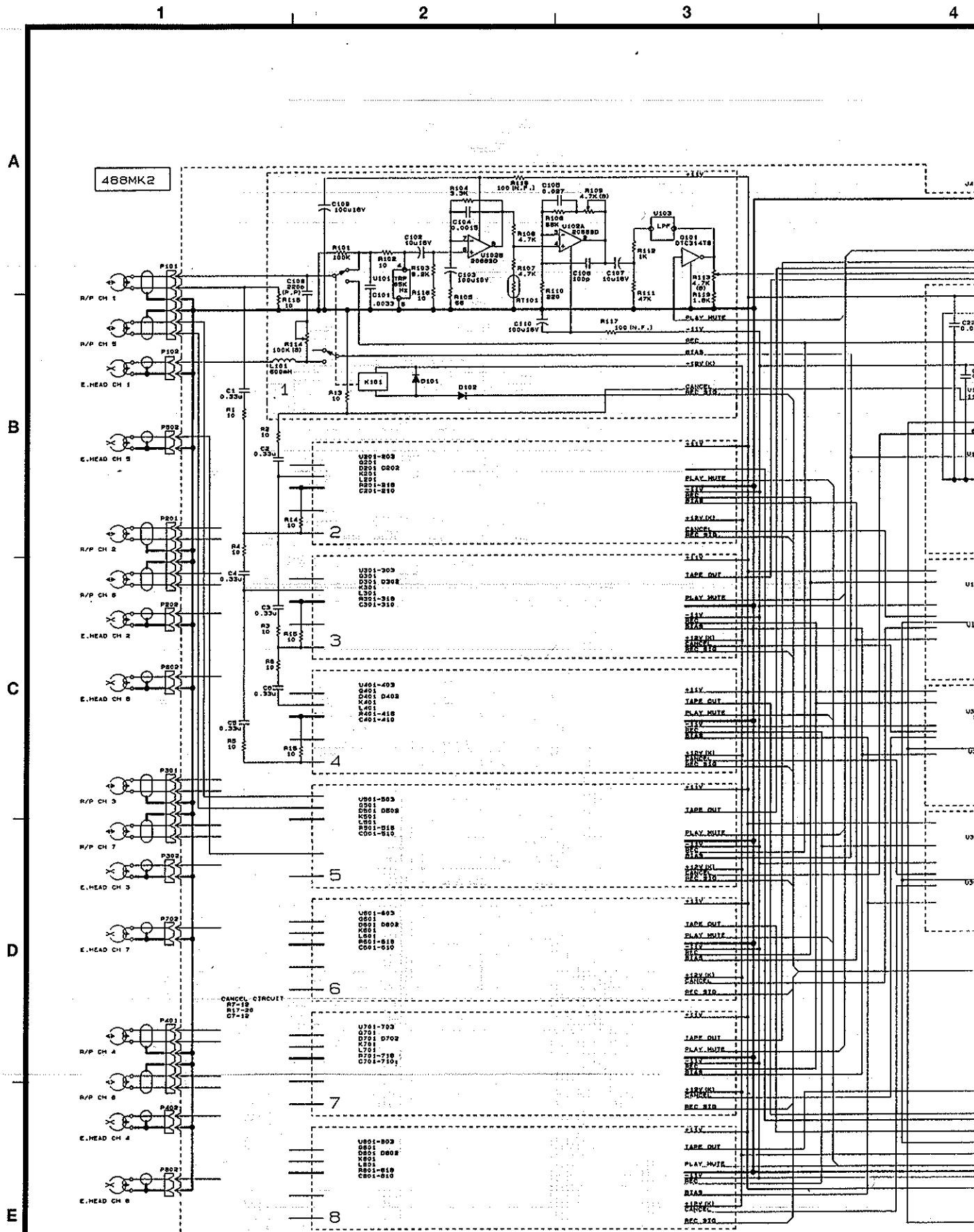

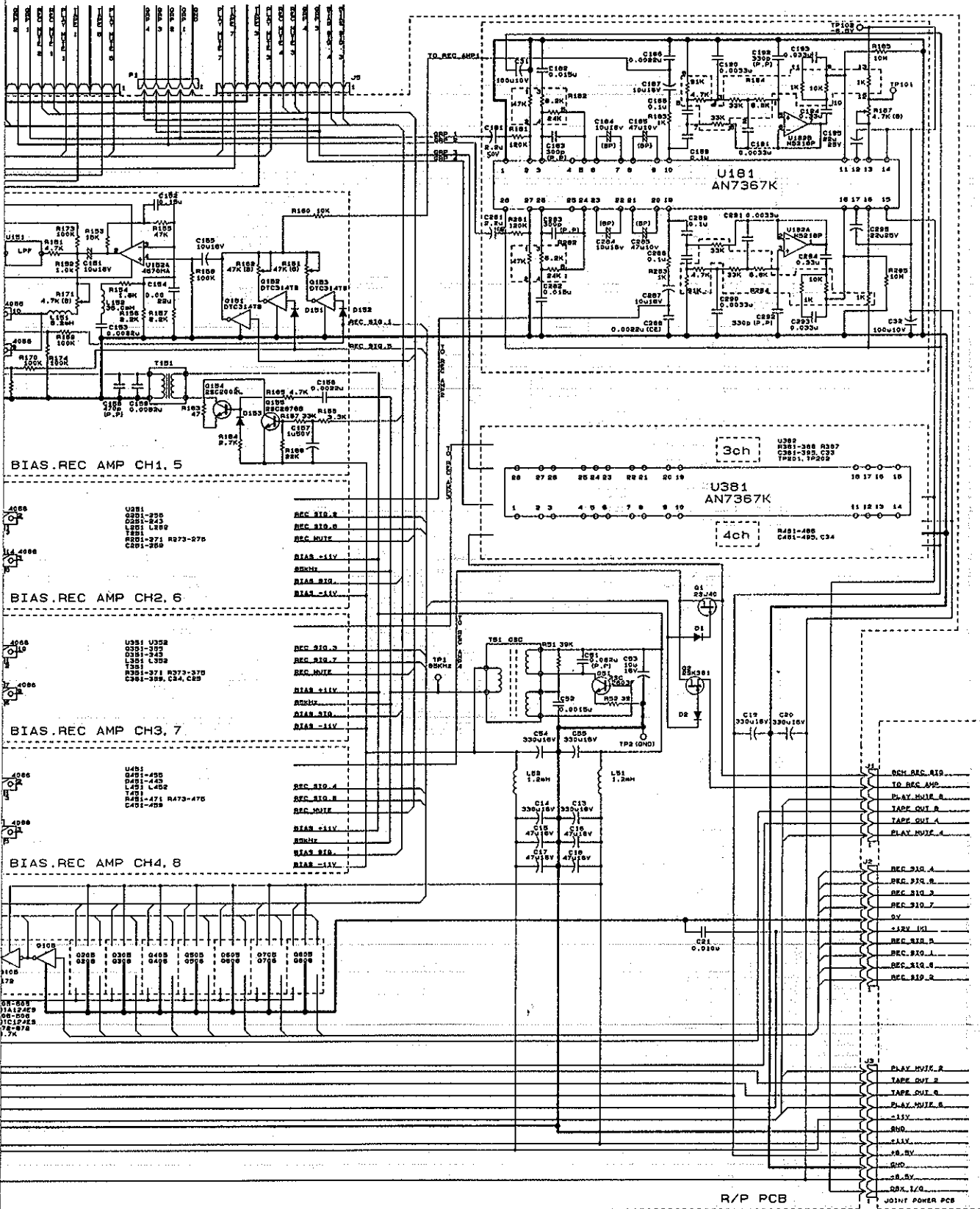

PORTASTUDIO 488MK II II

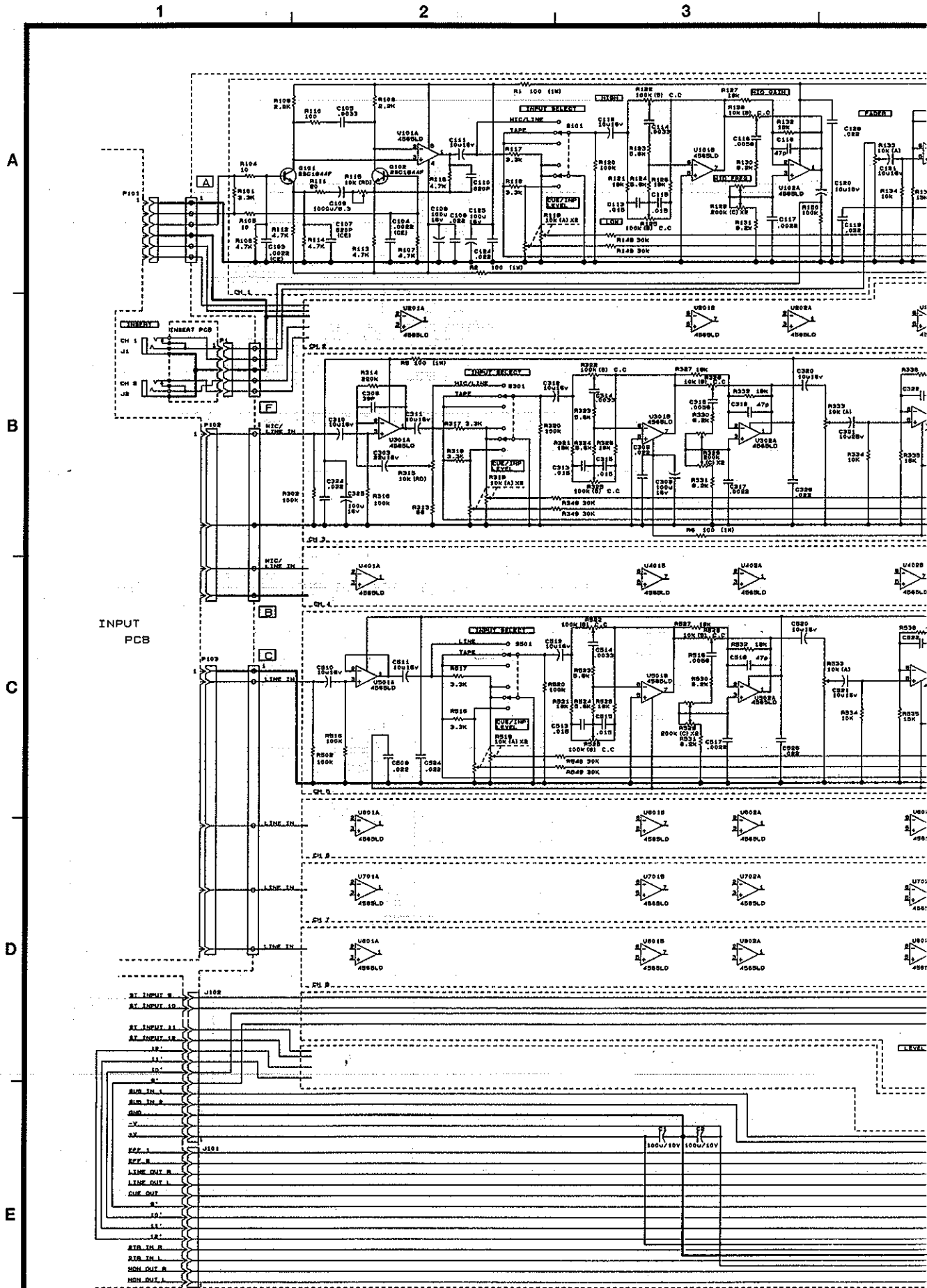

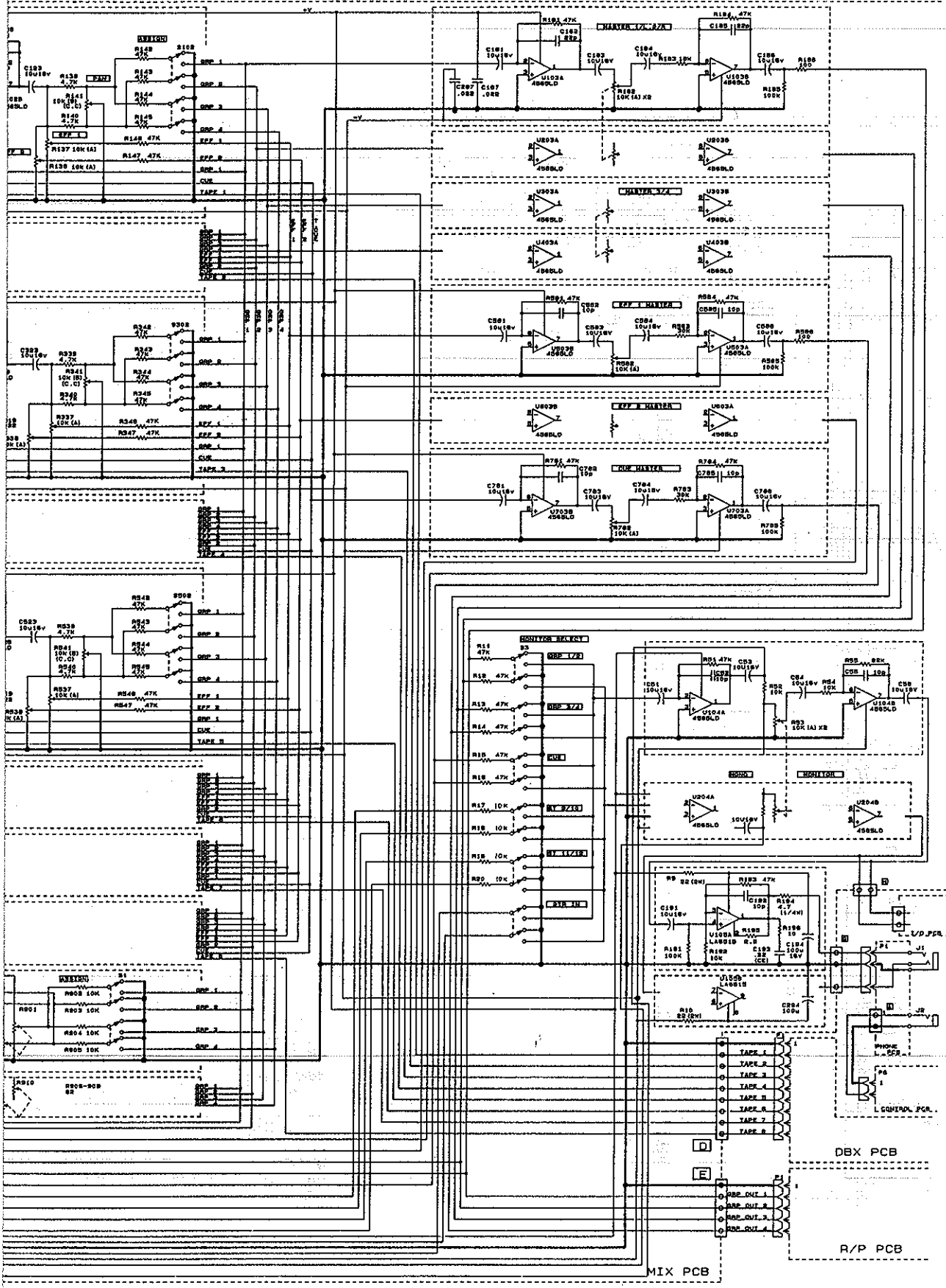

PORTASTUDIO 488MKII

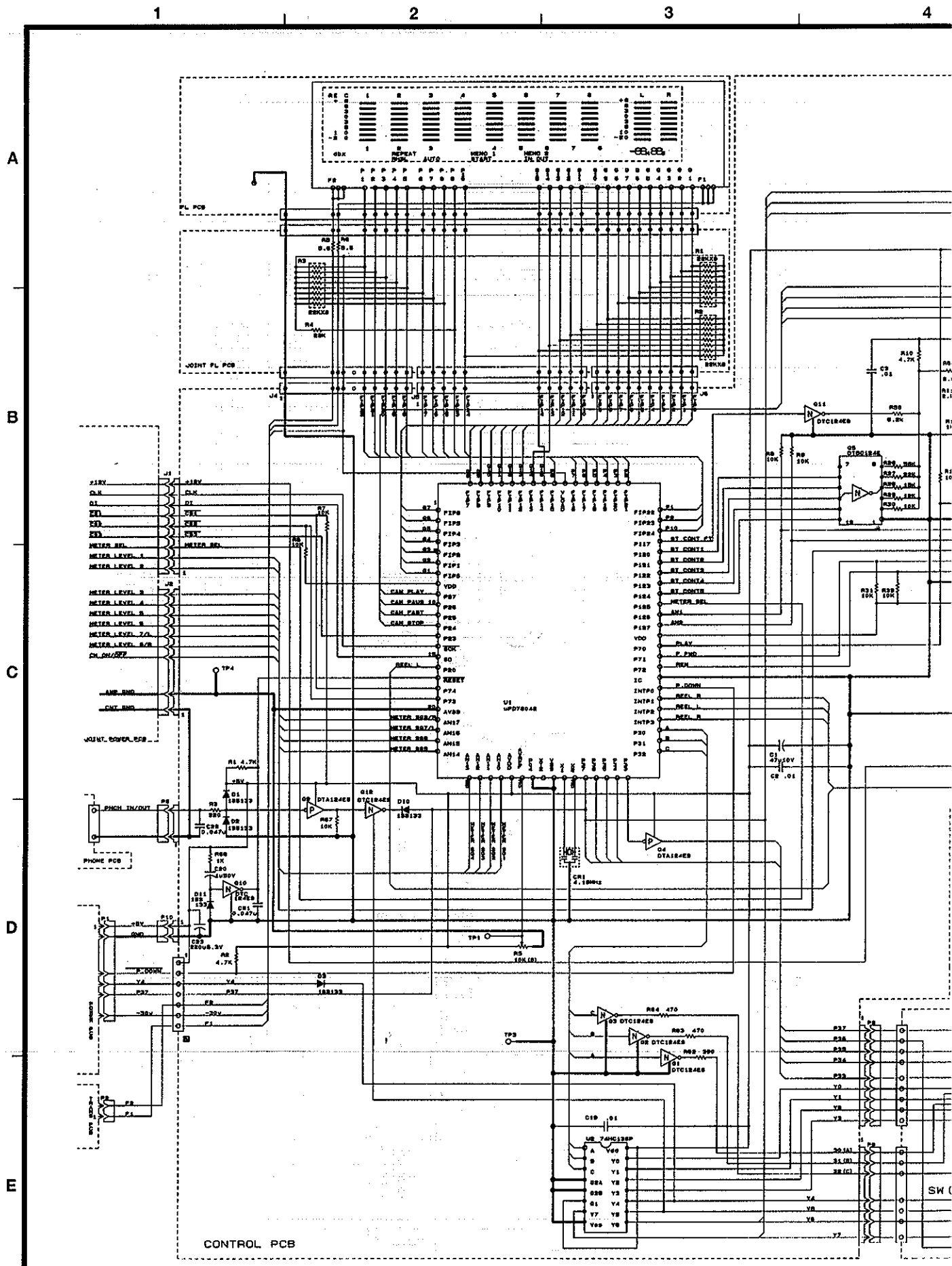

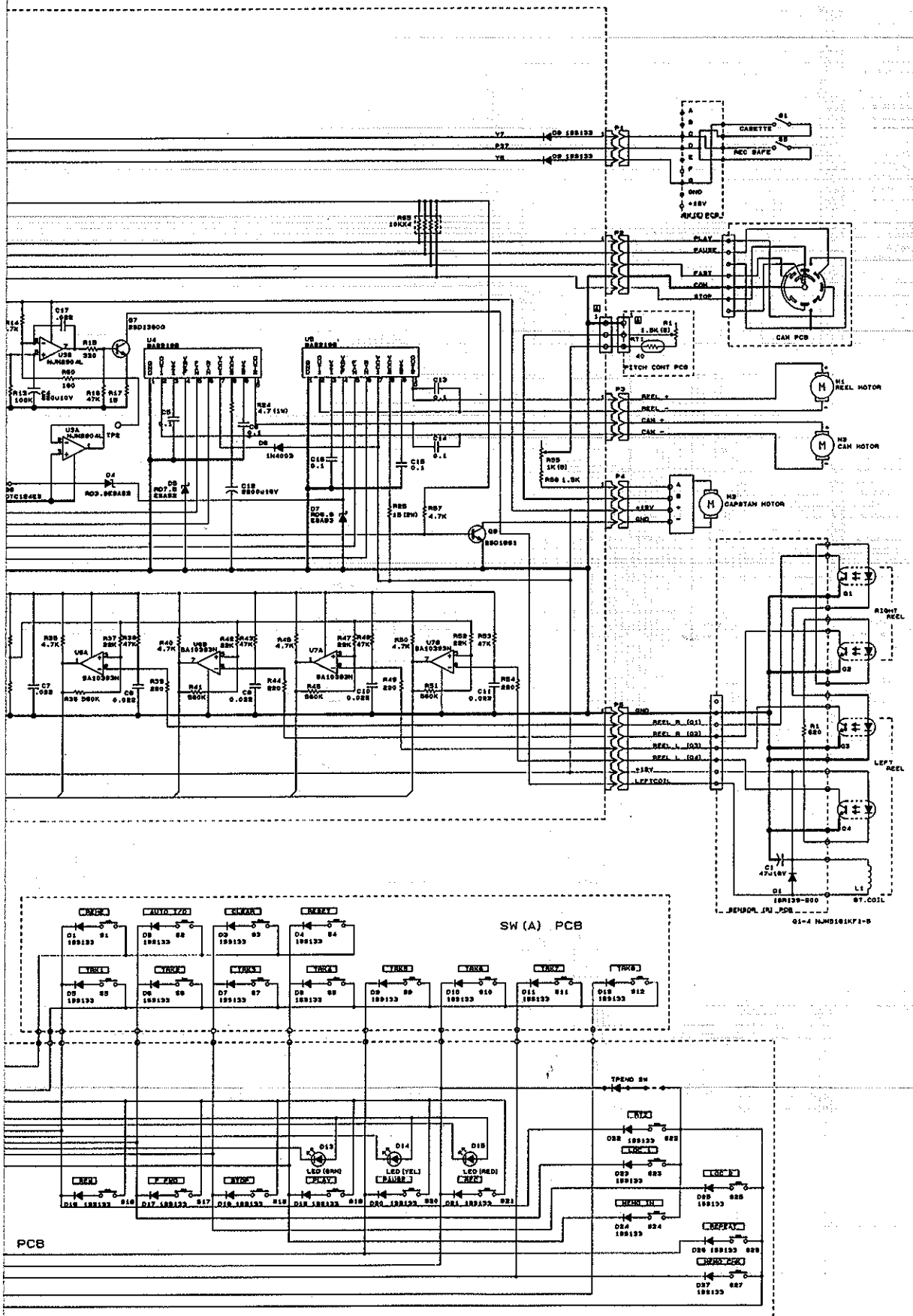

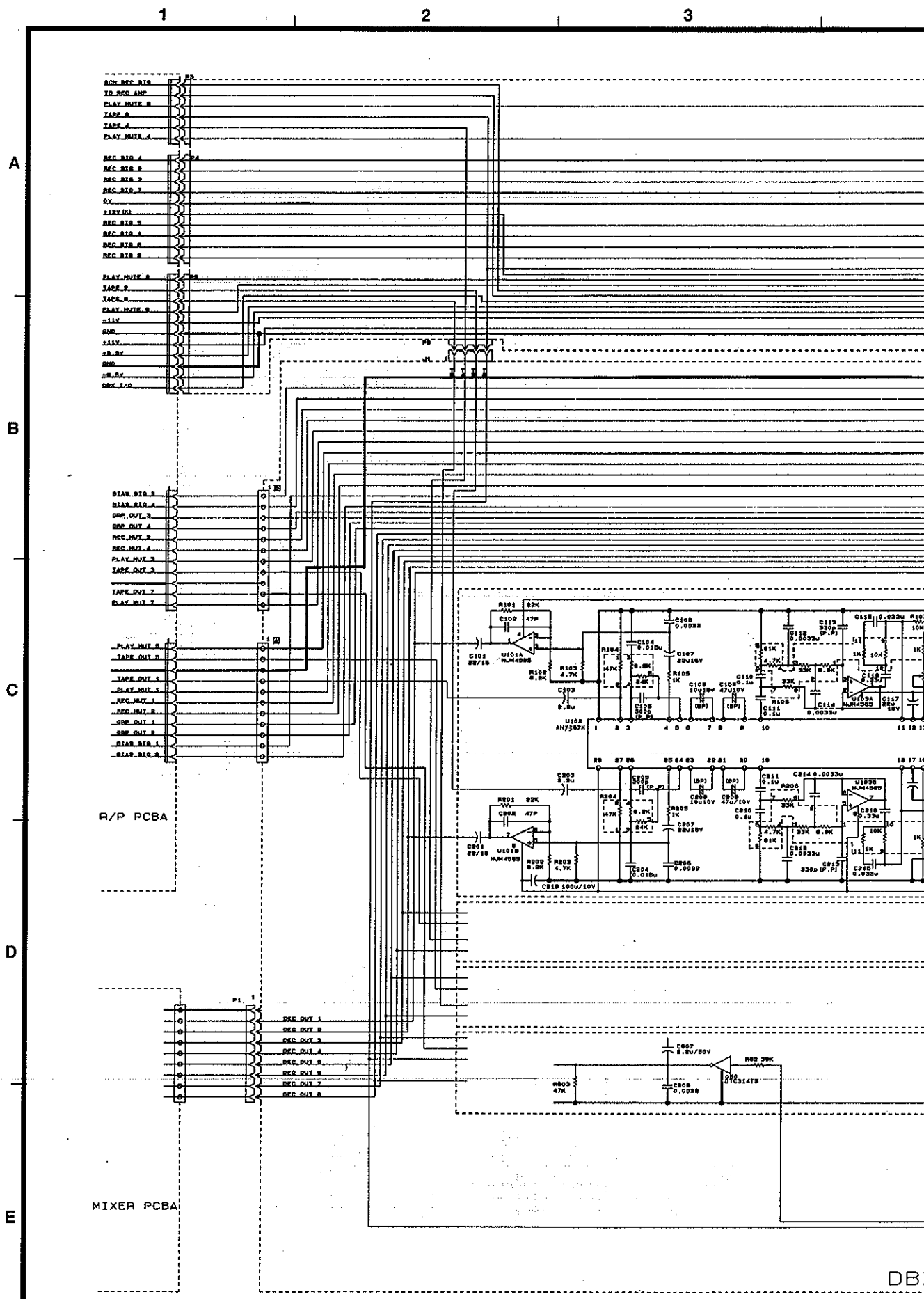

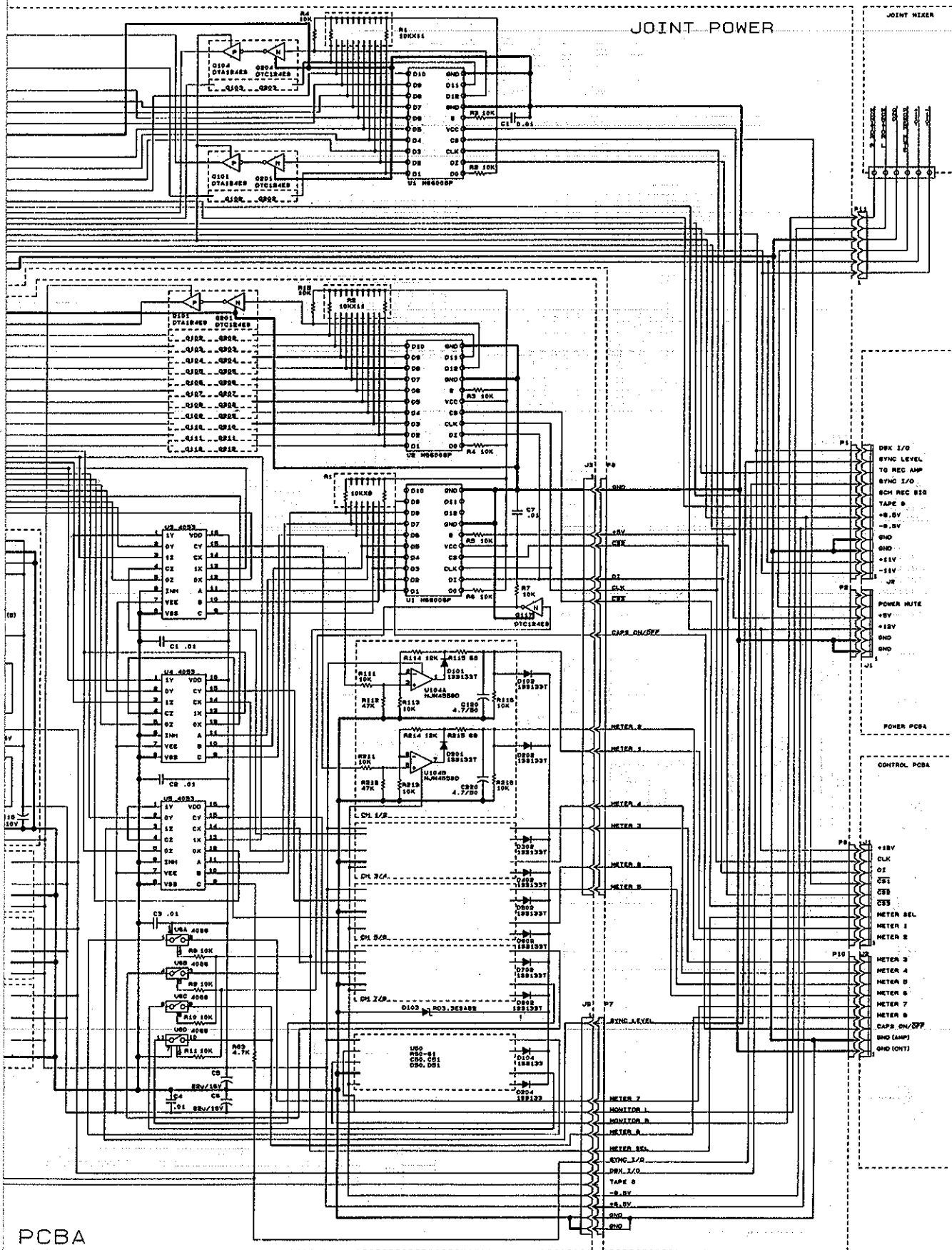

PORTASTUDIO 488MKII

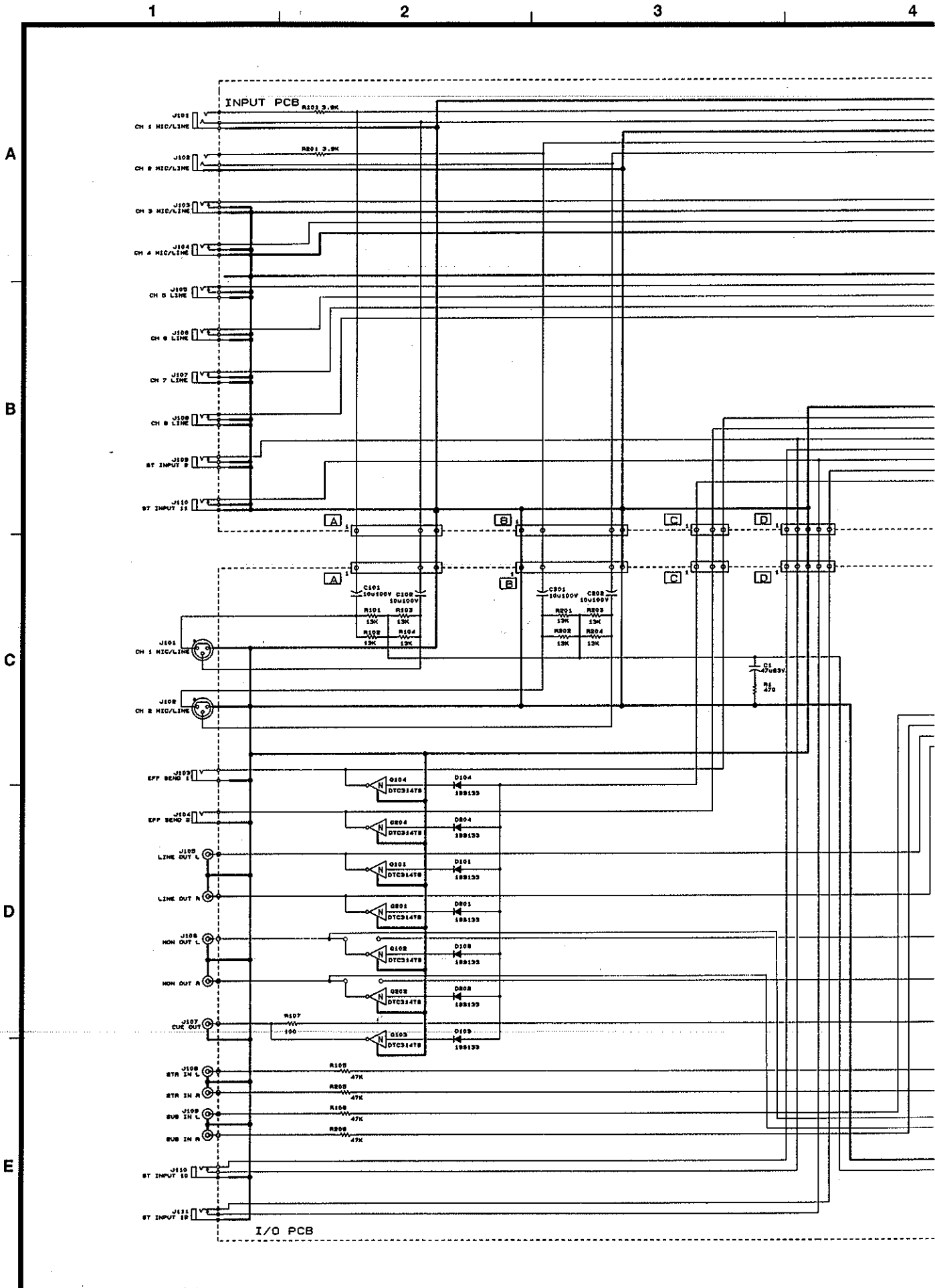

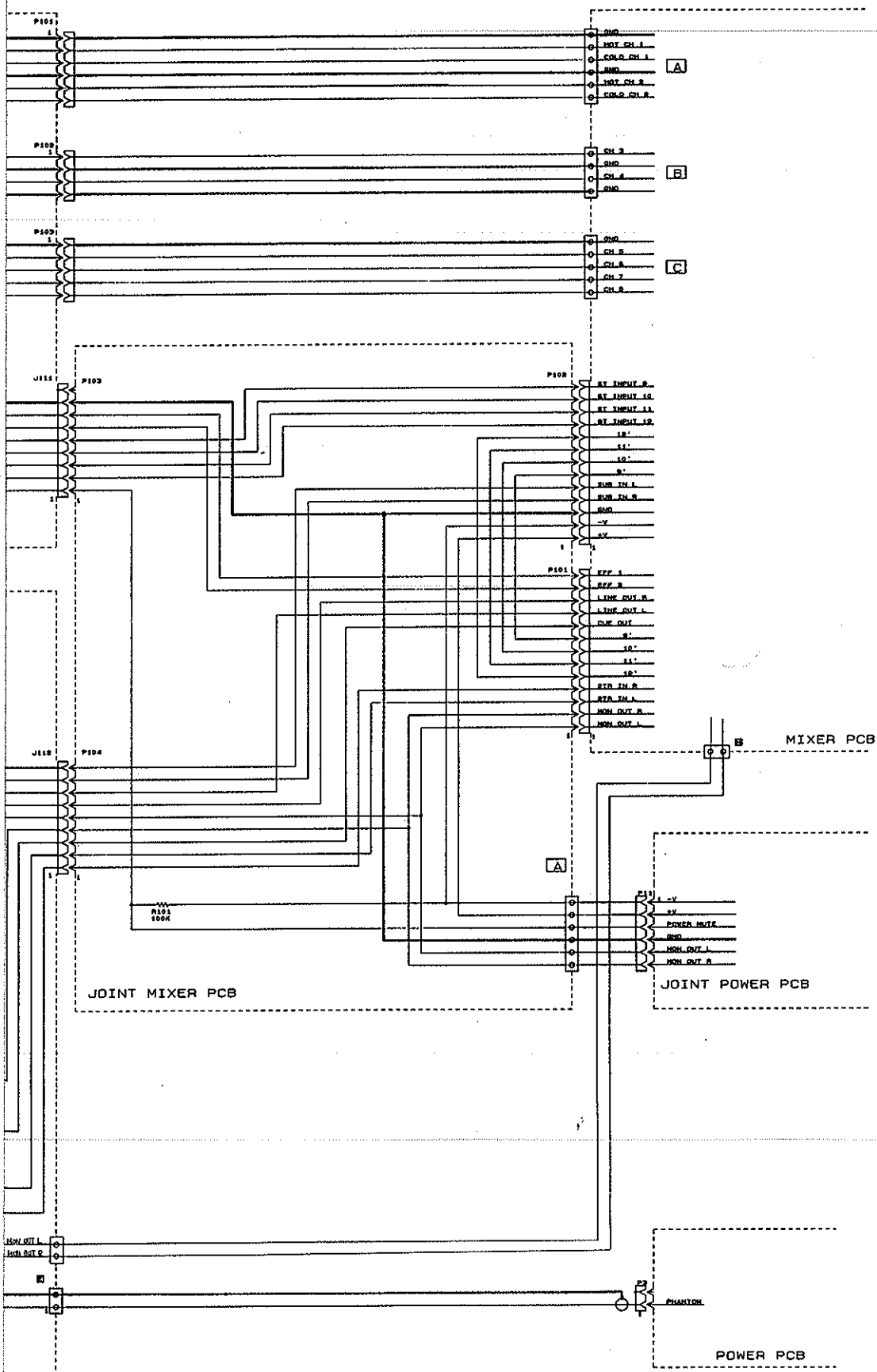

PORTASTUDIO 488MKII