

TASCAM

TEAC Professional Division

SERVICE MANUAL

414

PORTASTUDIO

NOTES

As regards the resistors and capacitors, refer to the circuit diagrams and the PCB ass'y drawings contained in this manual.

- * PC boards shown viewed from parts side.
- * Parts marked with * require longer deliver time.
- * Δ Parts marked with this sign are safety critical components. They must always be replaced with identical components – refer to the TEAC Parts List and ensure exact replacement.
- * Parts not shown in the parts lists, or parts, though listed, having no parts numbers, are not general "ready-to-supply" parts.
- * Parts of [] mark can be used only with the version designated.
[US/C]: U. S. A. /CANADA [E]: EUROPE [UK]: U. K. [A]: AUSTRALIA
[J]: JAPAN

注意

標準抵抗、コンデンサーは省略してあります。回路図および基板図を参照してください。

- プリント基板図は部品面が示されています。
- *印の部品は納期が若干かかります。あらかじめご了承ください。
- Δ 印は安全規格重要部品です。交換するときは必ずティアック指定の部品を使用してください。
- リストされていない部品は原則としてサービス供給部品として取扱っていません。
- 仕向先
[US/C]: U. S. A. /CANADA [E]: EUROPE [UK]: U. K. [A]: AUSTRALIA
[J]: JAPAN

INSTRUCTIONS FOR SERVICE PERSONNEL

BEFORE RETURNING APPLIANCE TO THE CUSTOMER, MAKE LEAKAGE-CURRENT OR RESISTANCE MEASUREMENTS TO DETERMINE THAT EXPOSED PARTS ARE ACCEPTABLY INSULATED FROM THE SUPPLY CIRCUIT.

1. SPECIFICATIONS

仕様

MECHANICAL

Type : Compact cassette (C-30 to C-90), High-Bias (CrO₂)

Track Format : 4-track/4-channel

Head Configuration :

4-channel record/play head (permalloy) × 1

4-channel erase head (ferrite) × 1

Motor : DC servo motor × 1

Tape Speed : 9.5 cm/sec. (3-3/4 ips)

Pitch Control : ± 12% (approx.)

Wow and Flutter : 0.12% WRMS or less

Fast Winding Time : 110 sec.(approx.) with C-60

ELECTRONICS

Mixer Section

MIC/LINE INPUT, Ch.1-4

Input Impedance : 50k ohms

Nominal Input Level :-50 dBV (3 mV) (Trim Max.)

-10 dBV (0.3 V) (Trim Min.)

Maximum Input Level :+5 dBV (1.8 V) at Trim Min.

STEREO INPUT, Ch.5-6/ Ch.7-8 (1/4" phone jack x 2)

Input Impedance : 10 kohms

Nominal Input Level :-10 dBV (0.3 V)

Maximum Input Level :+5 dBV (1.8 V)

SUB INPUT (RCA jack x 2)

Input Impedance : 10 kohms

Nominal Input Level :-10 dBV (0.3 V)

Maximum Input Level :+5 dBV (1.8 V)

LINE OUTPUT (RCA jack x 2)

Output Impedance : 100 ohms

Nominal Output Level :-10 dBV (0.3 V)

Maximum Output Level :+5 dBV (1.8 V)

EFFECT 1 SEND (1/4" phone jack)

Output Impedance : 100 ohms

Nominal Output Level :-10 dBV (0.3 V)

Maximum Output Level :+5 dBV (1.8 V)

EFFECT 2 SEND/TAPE CUE OUT (1/4" phone jack)

Output Impedance : 100 ohms

Nominal Output Level :-10 dBV (0.3 V)

Maximum Output Level :+5 dBV (1.8 V)

SYNC OUT (RCA jack x 1)

Output Impedance : 100 ohms

Nominal Output Level :-10 dBV (0.3 V)

MON OUT (RCA jack x 2)

Output Impedance : 600 ohms

Nominal Output Level :-10 dBV (0.3 V)

Maximum Output Level :+5 dBV (1.8 V)

PHONES (1/4" stereo phone jack x 1)

Nominal Load Impedance : 30 ohms

Maximum Output Level : 60 mW + 60 mW

Equalizer

HIGH (Shelving) : 10 kHz, ± 10 dB

LOW (Shelving) : 100 Hz, ± 10 dB

Frequency Response

MIC IN to LINE OUT : 20 Hz to 20 kHz, ± 3 dB

LINE IN to LINE OUT : 20 Hz to 20 kHz, ± 2 dB

LINE IN to MONITOR OUT : 20 Hz to 20 kHz, ± 3 dB

LINE IN to EFFECT SEND : 20 Hz to 20 kHz, ± 2 dB

LINE IN to PHONES : 40 Hz to 20 kHz, ± 3 dB

Signal-to-Noise Ratio (20 Hz to 20 kHz, B.P.F. inserted)

1 MIC IN to LINE OUT :

63 dB (at a nominal input level of -60 dBV)

4 MIC INs to LINE OUT :

58 dB (at a nominal input level of -60dBV)

1 LINE IN to LINE OUT :

70 dB (at a nominal input level of -10dBV)

4 LINE INs to LINE OUT :

65 dB (at a nominal input level of -10dBV)

Distortion

1 MIC IN to LINE OUT : 0.05% (at 1 kHz, 15 dB above nominal input level with 30 kHz-L.P.F. inserted)

1 LINE IN to LINE OUT : 0.05% (at 1 kHz, nominal input level with 30 kHz-L.P.F. inserted)

Crosstalk : 55 dB (at 1 kHz, nominal input level with 1 kHz-B.P.F. inserted)

Recorder Section**Record channel** : 4-track single direction**Noise Reduction** : dbx Type II**Overall Frequency Response** :40 Hz to 16 kHz, ± 3 dB (without dbx)**Overall Signal-to-Noise Ratio** : 85 dB

(at 1 kHz, ref. to 3 % THD, "A" weighted, with dbx)

Total Harmonic Distortion : 1.0 %

(at 1 kHz, nominal input level, with dbx)

Channel Separation : 70 dB

(at 1 kHz, nominal input level, with dbx)

Erasure : 70 dB or better (at 1 kHz, B.P.F. inserted)**OTHERS****Power Requirements :****USA/CANADA** : 120 V AC, 60 Hz**U.K./EUROPE** : 230 V AC, 50 Hz**AUSTRALIA** : 240 V AC, 50 Hz**JAPAN** : 100 V AC, 50-60 Hz**Power Consumption** : 11W**Dimensions (W x H x D)** :

367 × 100 × 247 mm (14-7/16" × 3-15/16" × 9-3/4")

Weight (Net) : 2.1 kg (4-10/16 lbs.)

In these specifications, 0 dBV is referenced to 1 Volt. Actual voltage levels are also given in parenthesis (0.316 V for -10 dBV rounded off to 0.3 V).

* dbx is a registered trademark of dbx Incorporated.

* Changes in specifications and features may be made without notice or obligation.

* dbxおよびdbxマークはdbxインコーポレーテッドの登録商標です。

* dbxシステムはdbxインコーポレーテッドの実地権に基づいて製造されています。

*仕様および外観は、改善のため予告なく変更することがあります。

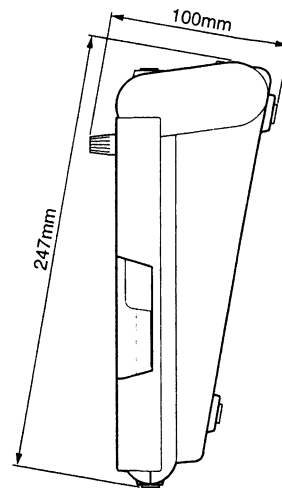
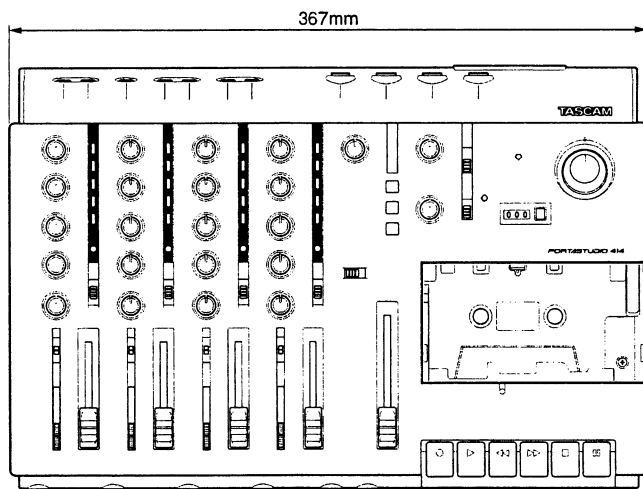

2. MECHANICAL CHECKS AND ADJUSTMENTS

機構部の確認と調整

2-1. Wow and flutter

1. Connect the wow and flutter meter to SYNC OUT.
2. The wow and flutter value when the test tape MXT-111 is played back should be within the standard given below :

Standard : 0.2 % or less (WRMS)

2-1. ワウ・フラッタ

1. SYNC OUTにワウ・フラッタ・メータを接続する。
2. テスト・テープMXT-111を再生したときのワウ・フラッタ値は下記規格内であること。

規格 : 0.2 %以下 (WRMS)

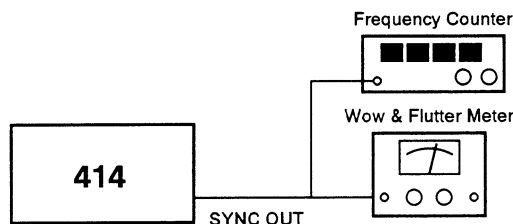

Fig. 2-1

2-2. Tape speed

1. Connect the frequency counter to SYNC OUT.
2. Set the PITCH CONTROL knob to the center position.
3. Turn the POWER switch ON, then play back the test tape. Leave the tape in this state for at least one minute, in order to let the capstan motor rotate and warm up.
4. Play back the middle portion of the test tape MXT-111, then adjust trimmer resistor R622 (Fig. 3-1) on the BOTTOM PCB till a frequency counter reading of 3000 Hz \pm 5 Hz is reached.
5. After adjustment, check the following at both the beginning and the end of tape.

Frequency reading : 3000 Hz \pm 60 Hz

2-3. Pitch control

After the tape speed has been adjusted, play back the test tape MXT-111, turn the PITCH CONTROL knob to the maximum and minimum positions so that the tape speed variations are as follows :

Standard : \pm 10 % or more

(2700 Hz or less, 3300 Hz or more)

2-2. テープ・スピード

1. SYNC OUTに周波数カウンタを接続する。
2. PITCH CONTROLノブをセンターにセットする。
3. キャプスタン・モータを回転させウォーミング・アップさせるために、テスト・テープを装着し再生状態にして少なくとも1分間そのままにしておく。
4. テスト・テープMXT-111の中間部を再生したとき、周波数カウンタの値が3000Hz \pm 5HzになるようにBOTTOM PCBの半固定抵抗R622 (図3-1)を調整する。
5. 調整後、テープの巻始めと巻終わり、次の値が得られるかを確認する。

速度偏差 : 3000Hz \pm 60Hz

2-3. ピッチ・コントロール

テープ・スピード調整後、テスト・テープMXT-111を再生し、PITCH CONTROLノブを最大、最小に回したときのテープ・スピード可変幅は次の通りであること。

規格 : \pm 10 %以上 (2700Hz以下、3300Hz以上)

2-4. Reel torque

1. Take-up torque/back tension torque

The torque values when the test tape MTT-8111 for measuring torques is played back should be as follows:

Take-up torque (right reel) : 30 to 65 g·cm

Back tension torque (left reel) : 2 to 6 g·cm

2. FF/REW torque

Load the test tape MTT-8242 for measuring torques, then measure the starting torque when the unit is in FF and REW operation. The standard values are as follows:

Torque in FF mode (right reel) : 55 to 140 g·cm

Torque in REW mode (left reel) : 55 to 140 g·cm

2-5. R/P head azimuth

1. Refer to Figure 2-2 and connect the channel 1 TAPE OUT to the vertical input of an oscilloscope, and connect the channel 4 TAPE OUT to the horizontal input of the scope.

2. Play the 315 Hz and 6.3 kHz signals on test tape MXT-1161 and adjust azimuth adjustment screw for 0 degree phase shift between channels 1 and 4. (Refer to Figure 2-3)

3. Play the test tape MXT-112 and check for 45 degrees or less of phase shift between channel 1 and 2, channel 2 and 3, and channel 2 and 4.

Note) TAPE OUT (CH1) – P601-5 of BOTTOM PCB
 TAPE OUT (CH2) – P601-6 of BOTTOM PCB
 TAPE OUT (CH3) – P601-7 of BOTTOM PCB
 TAPE OUT (CH4) – P601-8 of BOTTOM PCB

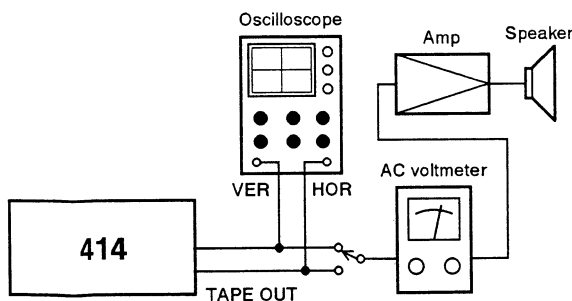

Fig. 2-2

2-4. リール・トルク

1. テイクアップ・トルク/バックテンション・トルク

トルク測定用テスト・テープ MTT-8111 を再生したときのトルク値は下記の通りであること。

テイクアップ・トルク (右リール台) : 30~65g・cm

バックテンション・トルク (左リール台) : 2~6g・cm

2. FF/REWトルク

トルク測定用テスト・テープ MTT-8242 を装着し、FF動作およびREW動作の起動トルクをそれぞれ測定する。規格値は次の通り。

FFトルク (右リール台) : 55~140g・cm

REWトルク (左リール台) : 55~140g・cm

2-5. 録再ヘッド・アジマス

1. 図2-2のようにCH1のTAPE OUTをオシロスコープのVER側に、CH4のTAPE OUTをHOR側に接続する。

2. テスト・テープ MXT-1161の315Hzおよび6.3kHzを再生して、CH1とCH4の位相が0°になるようにアジマス調整ネジを調整する。(図2-3)

3. テスト・テープ MXT-112を再生して、CH1-CH2、CH2-CH3、CH2-CH4の位相が45°以内であることを確認する。

注) TAPE OUT (CH1) – BOTTOM PCBのP601-5
 TAPE OUT (CH2) – BOTTOM PCBのP601-6
 TAPE OUT (CH3) – BOTTOM PCBのP601-7
 TAPE OUT (CH4) – BOTTOM PCBのP601-8

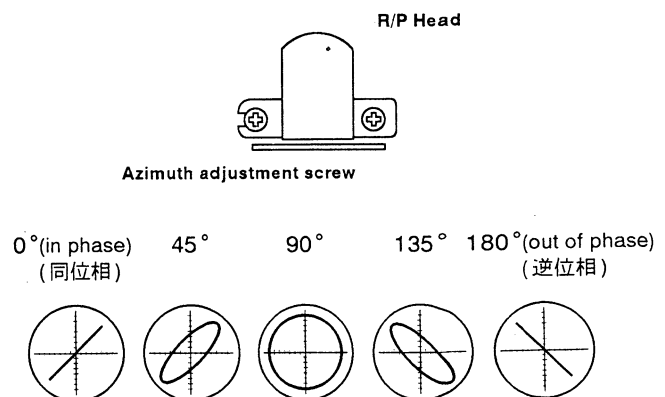
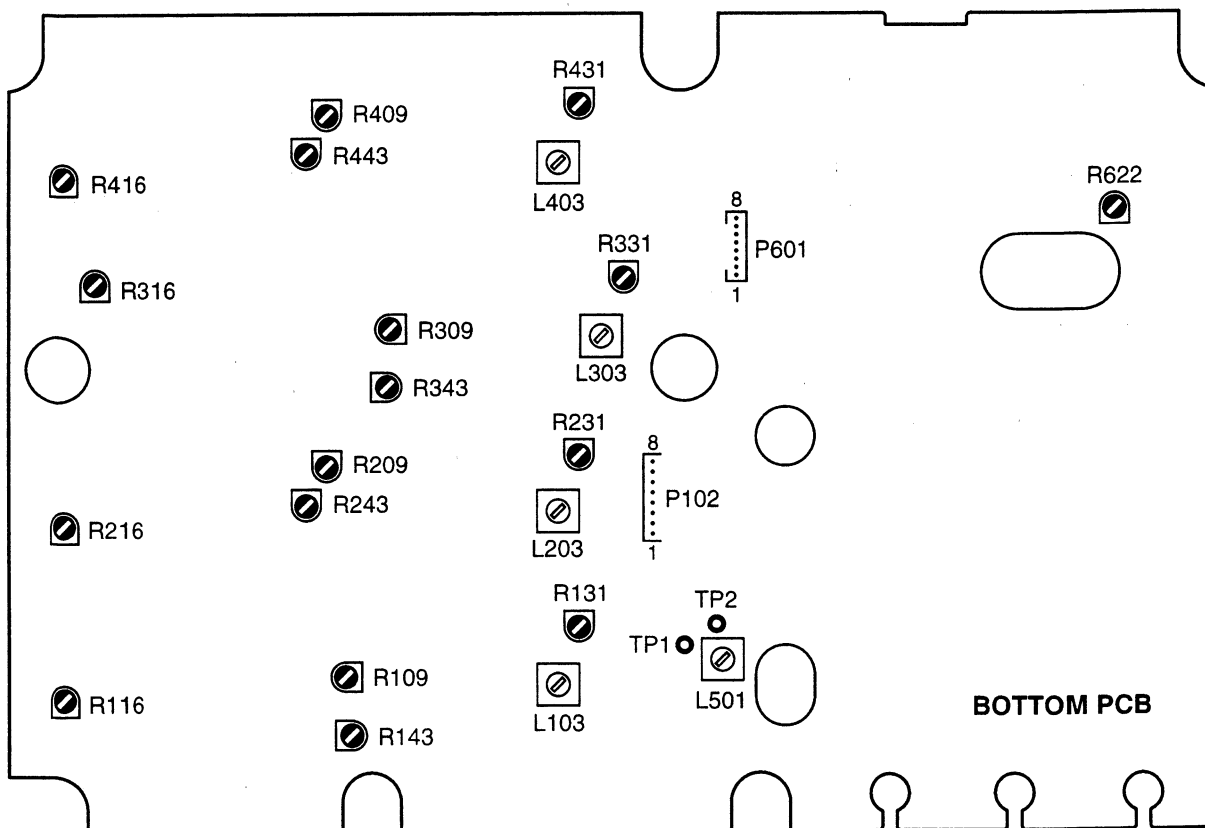

Fig. 2-3

3. AMPLIFIER CHECKS AND ADJUSTMENTS

録音・再生アンプの確認と調整



R109 (R209~R409)	Reproduce Reference Level	再生基準レベル
R116 (R216~R416)	dbx Timing	dbx タイミング
L501	Bias Oscillator Frequency	バイアス発振周波数
L103 (L203~L403)	Bias Amp (Erase)	バイアス・アンプ (消去)
R131 (R231~R431)	Bias Set	バイアス・セット
R143 (R243~R443)	Record Reference Level	録音基準レベル

Fig. 3-1 Adjustment and check points

調整箇所および測定箇所

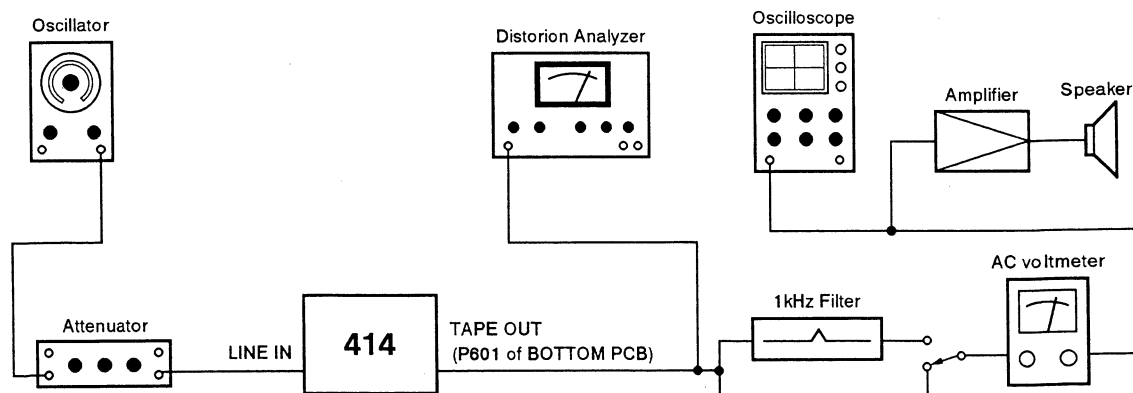

Fig. 3-2 Basic test setup

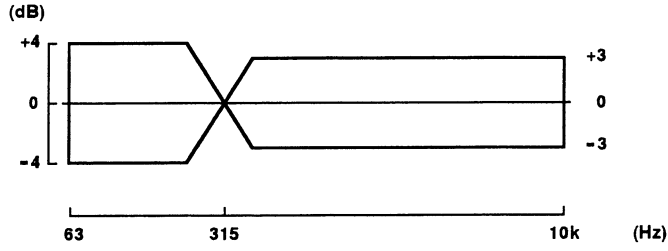

Fig. 3-3 Playback frequency
再生周波数特性

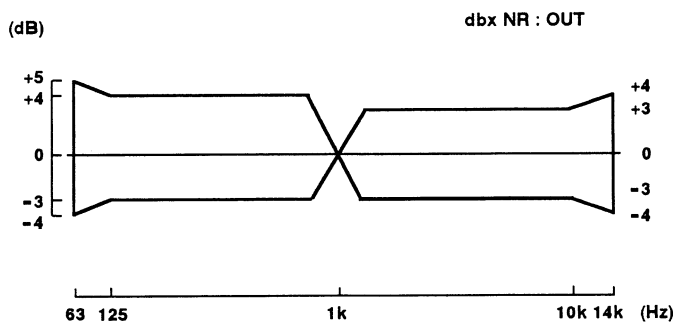
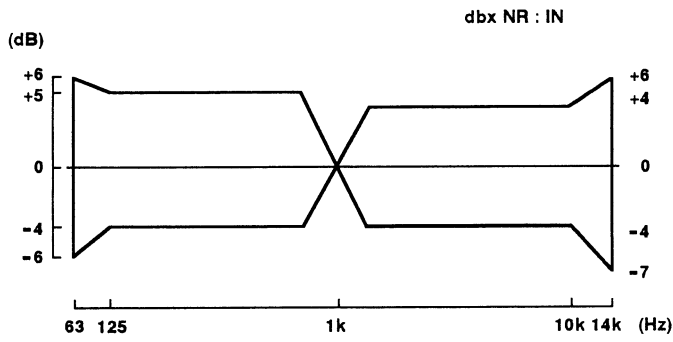

Fig. 3-4 Overall frequency response
録再周波数特性

3-1. Precautions

1. Before performing adjustments or checks, clean and demagnetize the entire tape path.
2. The AC voltmeter used in the procedures must have an input impedance of 1 M Ω or more.
3. 0 dBV corresponds 1.0 V.
4. For blank tape, use TEAC MTT-5563 or equivalent tapes.
5. Indication, for example, "R109 (R209 to R409)" means that R109 is for channel 1, R209 for channel 2, R309 for channel 3 and so on.
6. Refer to Figure 3-1 for location of adjustment points.

3-2. Playback System

Test Mode : PLAY

Measurement Point : TAPE OUT terminals

(TAPE OUT (CH1) - Pin 5 of BOTTOM PCB connector P601
 TAPE OUT (CH2) - Pin 6 of BOTTOM PCB connector P601
 TAPE OUT (CH3) - Pin 7 of BOTTOM PCB connector P601
 TAPE OUT (CH4) - Pin 8 of BOTTOM PCB connector P601)

Adjustment Item	Preliminary	Input Signal	Adjustment Point	Measurement Method / Value Adjusted For
1. Reproduce Reference Level	Connection : Fig. 3-2	MXT - 112	R109 (R209 to R409)	- 10 dBV at output
2. Reproduce Frequency Response	Connection : Fig. 3-2	MXT - 1161	Check only	Standard : Fig. 3-3
3. Level Difference between Channels	Connection : Fig. 3-2	Same as above	Check only	63 Hz to 6.3 kHz : within 3 dB 6.3 kHz to 10 kHz : within 4 dB
4. Level Fluctuation	Connection : Fig. 3-2	Same as above	Check only	63 Hz to 6.3 kHz : within 2 dB 6.3 kHz to 12 kHz : within 3 dB
5. Reproduce S/N Ratio	Connection : Fig. 3-2 ; DIN AUDIO	—	Check only	Measure output when leader tape is played back with the unit set for nominal output level , and compare this reading with nominal output level : 47 dB or more Defference between channels : within 4 dB

3-3. Recording System

Test Mode : REC/PLAY (unless otherwise specified)

Measurement Point : TAPE OUT terminals (unless otherwise specified)

Adjustment Item	Preliminary	Input Signal	Adjustment Point	Measurement Method / Value Adjusted For
1. dbx Timing	Connect the DC voltmeter between the pin 1 of R116 (R216 to R416) and GND.	—	R116 (R216 to R416)	A voltage reading of 18.4 ± 1 mV
2. Bias Oscillator Frequency	Frequency counter connected between TP1 (GND) and TP2 ; REC FUNCTION sw. : ON for all channels ; Transport : REC/PAUSE	—	L501	85 kHz \pm 5 kHz as read on frequency counter

Adjustment Item	Preliminary	Input Signal	Adjustment point	Measurement Method / Value Adjusted For
3. Bias Amp (Erase)	Oscilloscope connected between terminals #1 (3, 5,7) and GND of P102 (with the scope's probe set to $\times 10$); REC FUNCTION sw.: ON for all channels; Transport: REC/PAUSE	—	L103 (L203 to L403)	Maximum output as read on the scope connected between the specified terminals of P102: Terminals #1 and GND – for Ch.1 Terminals #3 and GND – for Ch.2 Terminals #5 and GND – for Ch.3 Terminals #7 and GND – for Ch.4
4. Bias Set	Connection: Fig. 3-2; dBx NR: ON	1 kHz/10 kHz, -30 dBV	R131 (R231 to R431)	Same output level at 1 kHz and 10 kHz signals as read off tape during recording them one after another
5. Record Reference Level	Connection: Fig. 3-2; dBx NR: ON	1 kHz, -10 dBV	R143 (R243 to R443)	-10 dBV output as read off tape during recording
6. Record Distortion	Connection: Fig. 3-2; dBx NR: OFF	Same as above	Check only	Standard: 2.0 % or less
7. Rec/Repro Frequency Response	Connection: Fig. 3-2; dBx NR: ON/OFF	63 Hz to 14 kHz, -30 dBV	Check only	Specs: Fig. 3-4
8. Level Difference between Channels	Connection: Fig. 3-2; dBx NR: OFF	40 Hz to 10 kHz, -30 dBV	Check only	3 dB or less over 40 Hz to 6.3 kHz 4 dB or less over 6.3 kHz to 10 kHz
9. Level Fluctuation	Same as above	40 Hz to 10 kHz, -30 dBV	Check only	3 dB or less over 40 Hz to 10 kHz
10. Crosstalk between Tracks	Connection: Fig. 3-2; dBx NR: OFF; REC FUNCTION sw.: ON for Ch.1 and 3	125 Hz, -10 dBV into Ch.1 and 3; No signal into Ch.2 and 4	Check only	Record the input signal, then rewind the tape and play the recording. Compare the output from Ch.1 and Ch.3 with that from Ch.2 and 4.; Level difference: 35 dB or greater In a similar way, check also the reverse: leakage from Ch.2 and 4 into Ch.1 and 3.
11. Channel Separation	Connection: Fig. 3-2 (1 kHz B.P.F. inserted); REC FUNCTION sw.: ON for all channels; dBx NR: OFF	1 kHz, -10 dBV into Ch.1 and 3; No signal into Ch.2 and 4	Check only	Compare the output level from Ch.1 and 3 with that from Ch.2 and 4 as read off tape during recording.; Level difference: 40 dB or greater In a similar way, check also the reverse: leakage from Ch.2 and 4 into Ch.1 and 3.
12. Erase Efficiency	Connection: Fig. 3-2 (1 kHz B.P.F. inserted); dBx NR: OFF	1 kHz, 0 dBV	Check only	Erase a part of a recorded section and play the tape to compare the level from the remaining recorded section with that from erased section.; Level difference: 65 dB or greater
13. Rec/Repro S/N Ratio	Connection: Fig. 3-2; dBx NR: OFF; DIN AUDIO	No input	Check only	Compare the output from the "no-signal" recording with nominal output level.; Level difference: 45 dB or greater Difference between channels: 4 dB or less

3-1. 注意

1. アンプ部の調整の前に、消去ヘッド、録/再ヘッド、テープ走行部分をそれぞれ充分消磁し、クリーナ液で清掃して下さい。
2. レベル計は、入力インピーダンス $1M\Omega$ 以上のものを使用して下さい。
3. $0dBV = 1.0V$ で表示しています。
4. ブランク・テープは、TEAC MTT-5563 または相当品を使用して下さい。
5. R109 (R209~R409) と記されているボリュームの部番は、CH1 (CH2~CH4) を示します。
6. 調整箇所は、図3-1を参照して下さい。

3-2. 再生系

モード：PLAY

測定箇所：TAPE OUT 端子

(TAPE OUT (CH1) - BOTTOM PCBのP601-5
 TAPE OUT (CH2) - BOTTOM PCBのP601-6
 TAPE OUT (CH3) - BOTTOM PCBのP601-7
 TAPE OUT (CH4) - BOTTOM PCBのP601-8)

調整項目	準備・設定	入力信号	調整箇所	測定方法・調整値
1. 再生基準レベル	接続：図3-2	MXT - 112	R109 (R209~R409)	出力が $-10dBV$ になるように調整
2. 再生周波数特性	接続：図3-2	MXT - 1161	チェック	規格：図3-3
3. チャンネル間レベル差	接続：図3-2	同上	チェック	63Hz~6.3kHz : 3dB以内 6.3kHz~10kHz : 4dB以内
4. レベル変動	接続：図3-2	同上	チェック	63Hz~6.3kHz : 2dB以内 6.3kHz~12kHz : 3dB以内
5. 再生S/N	接続：図3-2 DIN AUDIO	—	チェック	基準出力状態で、リーダー・テープ部を再生した時のノイズ・レベルと基準出力との比： 47dB以上 チャンネル差 4dB以内

3-3. 録音系

モード：REC/PLAY（特に指示のある場合を除く）

測定個所：TAPE OUT 端子（特に指示のある場合を除く）

調整項目	準備・設定	入力信号	調整個所	測定方法・調整値
1. dbx タイミング	R116 (R216~R416) の1番ピンとGND間にDC電圧計を接続	—	R116 (R216~R416)	電圧値が18.4 ± 1mVになるように調整
2. バイアス発振周波数	TP1 (GND) とTP2間に周波数カウンタを接続 REC FUNC. SW : 全ch ON REC/PAUSE状態	—	L501	周波数が85kHz ± 5kHzになるように調整
3. バイアス・アンプ (消去)	P102-1 (3, 5, 7) とGND間にオシロスコープを接続 (プローブは×10にて使用) REC FUNC. SW : 全ch ON REC/PAUSE状態	—	L103 (L203~L403)	下記の端子間の出力が最大になるように調整 CH1 : P102の1番端子-GND間 CH2 : P102の3番端子-GND間 CH3 : P102の5番端子-GND間 CH4 : P102の7番端子-GND間
4. バイアス・セット	接続：図3-2 dBx NR : ON	1kHz, 10kHz/ -30dBV	R131 (R231~R431)	録音・再生したとき、1kHzと10kHzが同レベルになるように調整
5. 録音基準レベル	接続：図3-2 dBx NR : ON	1kHz/-10dBV	R143 (R243~R443)	録音・再生したとき、出力が-10dBVになるように調整
6. 録音歪率	接続：図3-2 dBx NR : OFF	同上	チェック	規格：2.0%以下
7. 録再周波数特性	接続：図3-2 dBx NR : ON, OFF	63Hz~14kHz/ -30dBV	チェック	規格：図3-4
8. チャンネル間レベル差	接続：図3-2 dBx NR : OFF	40Hz~10kHz/ -30dBV	チェック	録再周波数特性規格内におけるch間のレベル差： 40Hz~6.3kHz : 3dB以内 6.3kHz~10kHz : 4dB以内
9. レベル変動	同上	40Hz~10kHz/ -30dBV	チェック	録再周波数特性規格内におけるレベル変動： 40Hz~10kHz : 3dB以内
10. トラック間クロストーク	接続：図3-2 dBx NR : OFF REC FUNC. SW : 1,3ch ON	1,3ch : 125Hz/ -10dBV 2,4ch : 無信号	チェック	録音・再生したときの1,3chの再生出力と2,4chの再生出力の比： 35dB以上 2,4ch → 1,3chの場合も同様
11. チャンネル・セパレーション	接続：図3-2 (1kHz B.P.F.使用) REC FUNC. SW : 全ch ON dBx NR : OFF	1,3ch : 1kHz/ -10dBV 2,4ch : 無信号	チェック	録音・再生したときの1,3chの再生出力と2,4chの再生出力の比： 40dB以上 2,4ch → 1,3chの場合も同様
12. 消去率	接続：図3-2 (1kHz B.P.F.使用) dBx NR : OFF	1kHz/0dBV	チェック	録音部分の一部を残して消去した後、再生したときの未消去部分との比： 65dB以上
13. 録再S/N	接続：図3-2 dBx NR : OFF DIN AUDIO	無信号	チェック	基準出力と無信号録再出力レベルとの比： 45dB以上 チャンネル差：4dB以内

4. EXPLODED VIEWS AND PARTS LIST

分解図とパーツリスト

EXPLODED VIEW-1

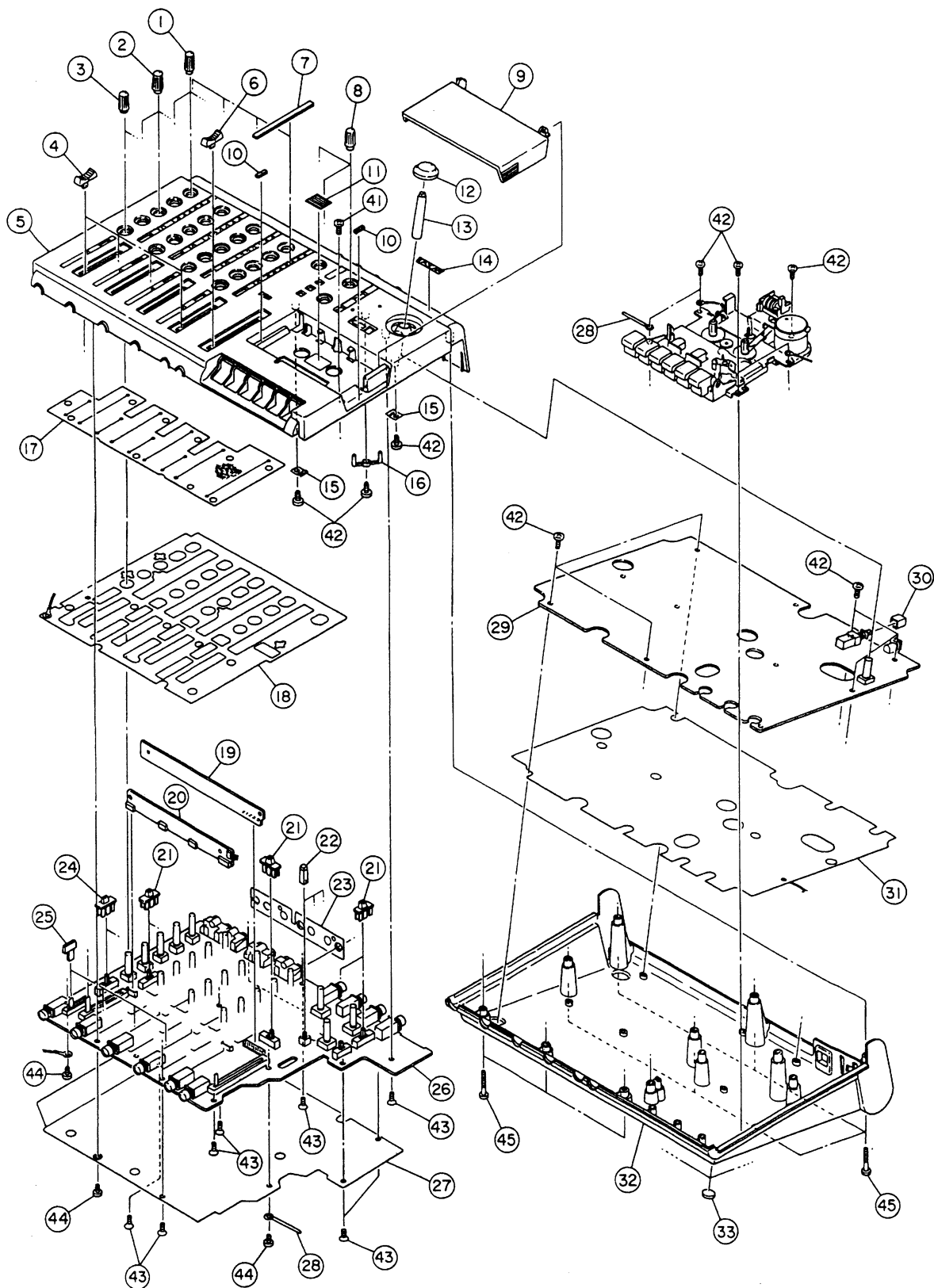

EXPLODED VIEW-1

REF. NO.	PARTS NO.	DESCRIPTION	REMARKS
1- 1	9260262700	KNOB, ROTARY N63/B09	
1- 2	9260262800	KNOB, ROTARY N63/G04	
1- 3	9260262900	KNOB, ROTARY N63/WHITE	
1- 4	M00004000A	KNOB, FADER OG	
1- 5	*9260271401	CABINET, TOP	
1- 6	M00004001A	KNOB, FADER RD	
1- 7	*9260271201	WINDOW, METER	
1- 8	9260269600	KNOB, ROTARY (ORANGE)	
1- 9	*9260282600	COVER, CASSETTE	
1-10	*9260225700	CUSHION, DOOR	
1-11	*9260205700	PLATE, REFLECT	
1-12	M00004200A	KNOB, PITCH GY	
1-13	9260271000	JOINT	
1-14	*9260271101	BADGE, TASCAM SILVER	
1-15	*9260282700	SPRING, COVER	
1-16	9260271600	LENS, LED	
1-17	*9260272100	BLIND, S-VR	
1-18	*9260272902	SHIELD SHEET, MIXER	
1-19	*9145200200	JUMP A PCB ASSY	
1-20	*9145200300	JUMP B PCB ASSY	
1-21	M00006100A	KNOB, SLIDE GY	
1-22	9260263300	KNOB, BUTTON COVER WHT/N63	
1-23	*9260283600	BLIND, PIN JACK	
1-24	M00462300A	KNOB, SLIDE	
1-25	9260271301	KNOB, TRIM	
1-26	*9145200100	MIXER PCB ASSY	
1-27	*9260282002	SHIELD ASSY	
1-28	*9788823059	HARNES CLIP, 3. 3X6. 0X54	
1-29	*9145201103	BOTTOM PCB ASSY	
1-30	5801503800	EJECT BUTTON, P-N15-A	
1-31	*9260272802	SHIELD SHEET, R/P	
1-32	*9260271501	CABINET, BOTTOM	
1-33	*9260262300	FOOT	
1-41	*9783613010	SCREW, BTT-P M3X10 (BLK)	
1-42	*9783603008	SCREW, BTT-P M3X8	
1-43	*9783133010	SCREW, FTT-P M3X10	
1-44	*9783603010	SCREW, BTT-P M3X10	
1-45	*9783613020	SCREW, BTT-P M3X20	

INCLUDED ACCESSORIES

REF. NO.	PARTS NO.	DESCRIPTION	REMARKS
	*9125115000	AC ADAPTOR, PS-P414 [US/C]	
	*9125115400	AC ADAPTOR, PS-P414 [A]	
	*9125115300	AC ADAPTOR, PS-P414 [UK]	
	*9125115800	AC ADAPTOR, PS-P414 [J]	
	*9125115200	AC ADAPTOR, PS-P414 [E]	
	*9101408400	OWNER'S MANUAL, ENGLISH [EXCEPT J]	
	*9101408500	OWNER'S MANUAL, FRENCH/GERMAN [E]	
	*9101408600	OWNER'S MANUAL, JAPANESE [J]	

EXPLODED VIEW-2

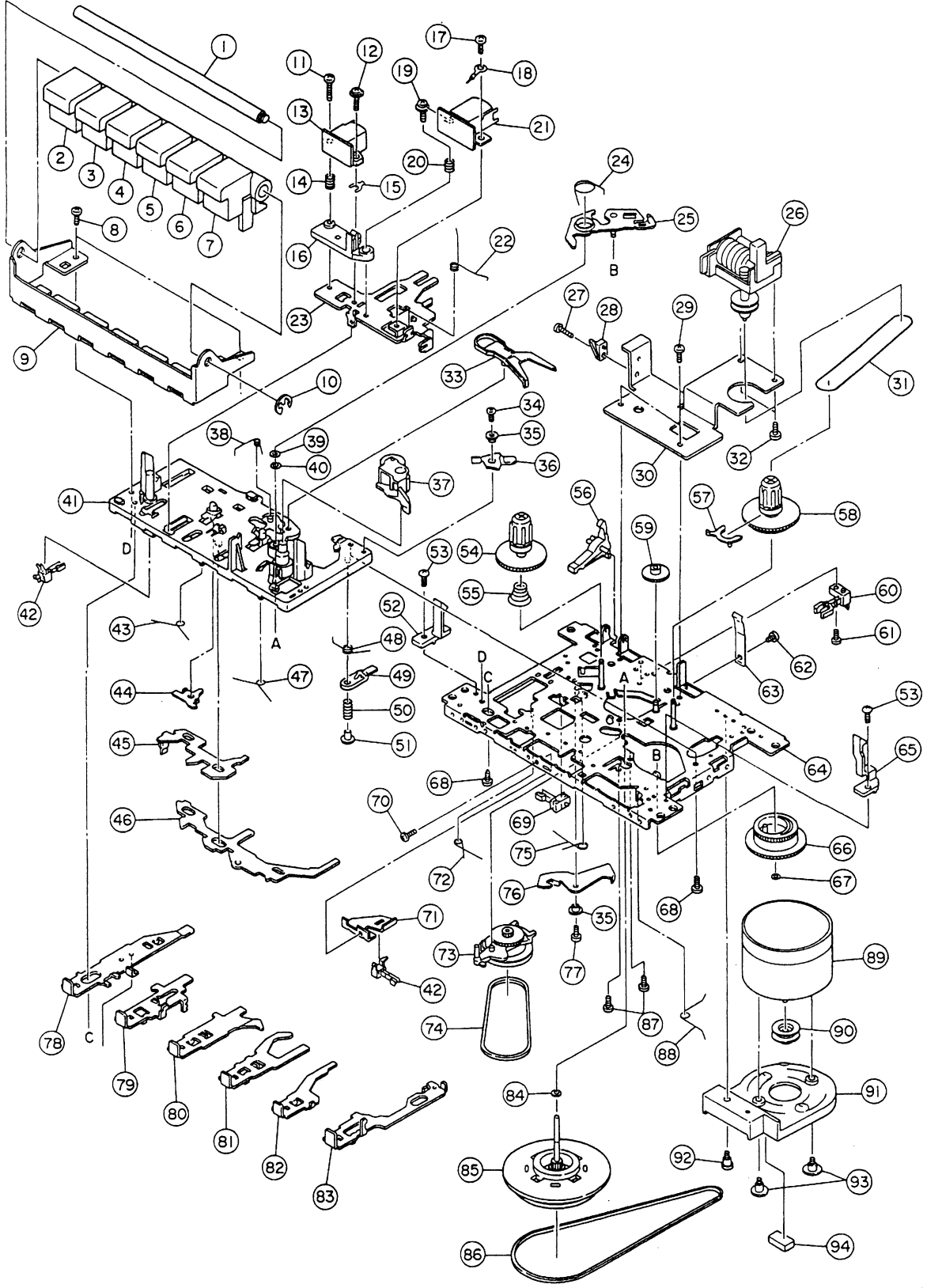

EXPLODED VIEW-2

REF. NO.	PARTS NO.	DESCRIPTION
2- 1	9278307000	BUTTON LEVER SHAFT
2- 2	9260272200	BUTTON (REC)
2- 3	9260272300	BUTTON (PLAY)
2- 4	9260272400	BUTTON (REW)
2- 5	9260272500	BUTTON (FF)
2- 6	9260272600	BUTTON (STOP)
2- 7	9260272700	BUTTON (PAUSE)
2- 8	*9278291700	TAPPING SCREW BTT-S M2X8
2- 9	*9278362800	B FRAME (H)
2-10	*9278362900	E-RING 3.2
2-11	*9278362300	SCREW M2X9
2-12	*9278362200	CAP SCREW M2X3
2-13	5378602100	ERASE HEAD 4-4
2-14	9278197900	E. H. SPRING
2-15	*9278305400	E HEAD SPACER
2-16	*9278305200	HEAD BASE
2-17	*9278362100	BIND SCREW M2X3
2-18	*9278361900	LUG PLATE(3B)2.0
2-19	*9278202700	AZIMUTH SCREW M2X7
2-20	9278198400	AZIMUTH SPRING
2-21	5378602000	R/P HEAD
2-22	*9278360700	PANEL P SPRING
2-23	*9278303800	HEAD PANEL
2-24	9278268900	GEAR PLATE SPRING
2-25	9278361100	GEAR PLATE ASSY
2-26	M00467400A	COUNTER, MK394S-008
2-27	*9783202006	SCREW, BTT-S M2X6
2-28	9135035800	PUSH SW, 1-1 SPPB22
2-29	*9783152006	SCREW, FTT-P M2X6
2-30	*9260270900	BRACKET, COUNTER
2-31	9260130700	COUNTER BELT
2-32	*9783132606	SCREW, FTT-P M2. 6X6
2-33	9278307300	SENSING LEVER
2-34	*9278363300	SCREW, PS-TITE M2X3
2-35	*9278292200	P ARM COLLAR
2-36	9278363100	P ARM
2-37	9278306800	PINCH ROLLER ARM ASSY
2-38	9278268600	M CONTROL SPRING
2-39	*9278362500	P WASHER CUT 1.45X3.2X0.5
2-40	*9278362700	P WASHER 2.1X4X0.13
2-41	*9278360200	BASE ASSY
2-42	9278304200	LEAF SWITCH, MSW-1541T
2-43	9278267300	BUTTON LEVER SPRING (A)
2-44	*9278267800	PR STOPPER
2-45	*9278304700	SWITCH ACTUATOR
2-46	*9278266201	PUSH BUTTON ACTUATOR
2-47	9278268000	BUTTON LEVER SPRING (B)
2-48	9278306400	P CONTROL SPRING
2-49	9278306500	PAUSE LEVER
2-50	9278267100	PAUSE LEVER SPRING

REF. NO.	PARTS NO.	DESCRIPTION
2-51	9278267200	PAUSE STOPPER
2-52	*9260223300	CASSETTE GUIDE (L)
2-53	*9783202006	SCREW, BTT-S M2X6
2-54	9278304800	SUPPLY REEL ASSY
2-55	9278361400	BACK TENSION SPRING
2-56	9278200300	RECORD SAFETY LEVER
2-57	9278306900	SENSOR
2-58	9278306600	TAKE UP REEL ASSY
2-59	9278199900	FF GEAR
2-60	9278304300	LEAF SWITCH, MSW-1275
2-61	*9278304600	TAPPING SCREW C-TITE M2X5
2-62	*9278362000	DEL TITE SCREW M2X3
2-63	9278305100	PACK SPRING
2-64	*9278360400	CHASSIS ASSY
2-65	*9260223400	CASSETTE GUIDE (R)
2-66	9278289100	CAM GEAR
2-67	*9278291400	P WASHER CUT 1.2X3.8X0.3
2-68	*9278202200	SCREW, P TAPPING BIND M2X5
2-69	9278292500	LEAF SW, MSW-17820-MVDO
2-70	*9278369100	CAMERA SCREW M2X5
2-71	*9278369000	SW BRACKET
2-72	9278267600	P. S. LEVER SPRING
2-73	9278361200	RF CLUTCH ASSY
2-74	9278289300	RF BELT
2-75	9278267900	REC BUTTON LEVER SPRING
2-76	9278363000	REC ARM
2-77	*9278202100	C TAPPING SCREW M2X4
2-78	9278266300	REC BUTTON LEVER
2-79	9278266400	PLAY BUTTON LEVER
2-80	9278360300	REW BUTTON LEVER
2-81	9278266600	FF BUTTON LEVER
2-82	9278303700	STOP BUTTON LEVER
2-83	9278306300	PAUSE BUTTON LEVER
2-84	*9278308400	P WASHER 2X3.5X0.4
2-85	9278361300	FLYWHEEL ASSY
2-86	9278361600	MAIN BELT
2-87	*9278291000	SCREW, TAPPING M2X4.5
2-88	9278267500	E ACTUATOR SPRING
2-89	9278361800	CAPSTAN MOTOR, EG-530KD-2F
2-90	9278361500	MOTOR PULLY
2-91	*9278304900	MOTOR BRACKET
2-92	*9278290400	MB SCREW
2-93	*9278290100	MOTOR COLLAR SCREW
2-94	*9278361700	ANTI VIBRATION FELT MAT

5. PC BOARDS AND PARTS LIST

基板図とパーツ・リスト

JUMP A PCB

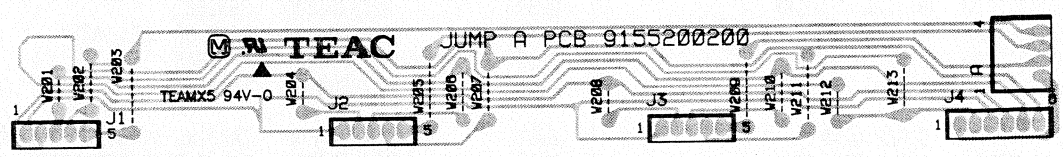

JUMP B PCB

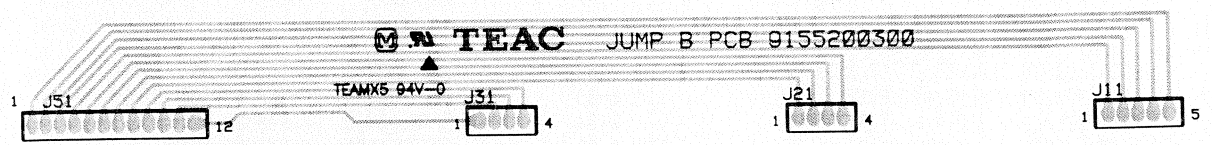

MIXER PCB

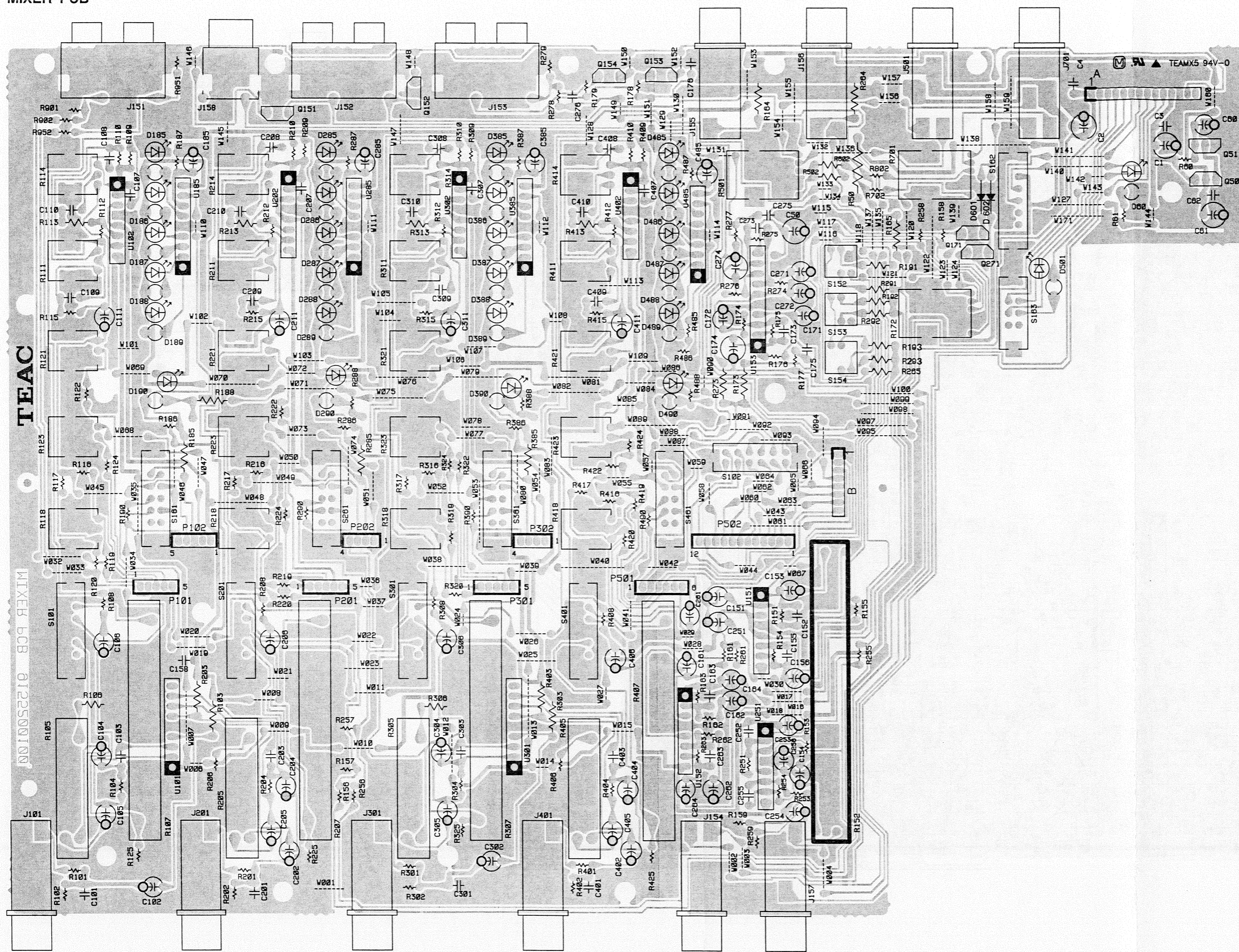

BOTTOM PCB

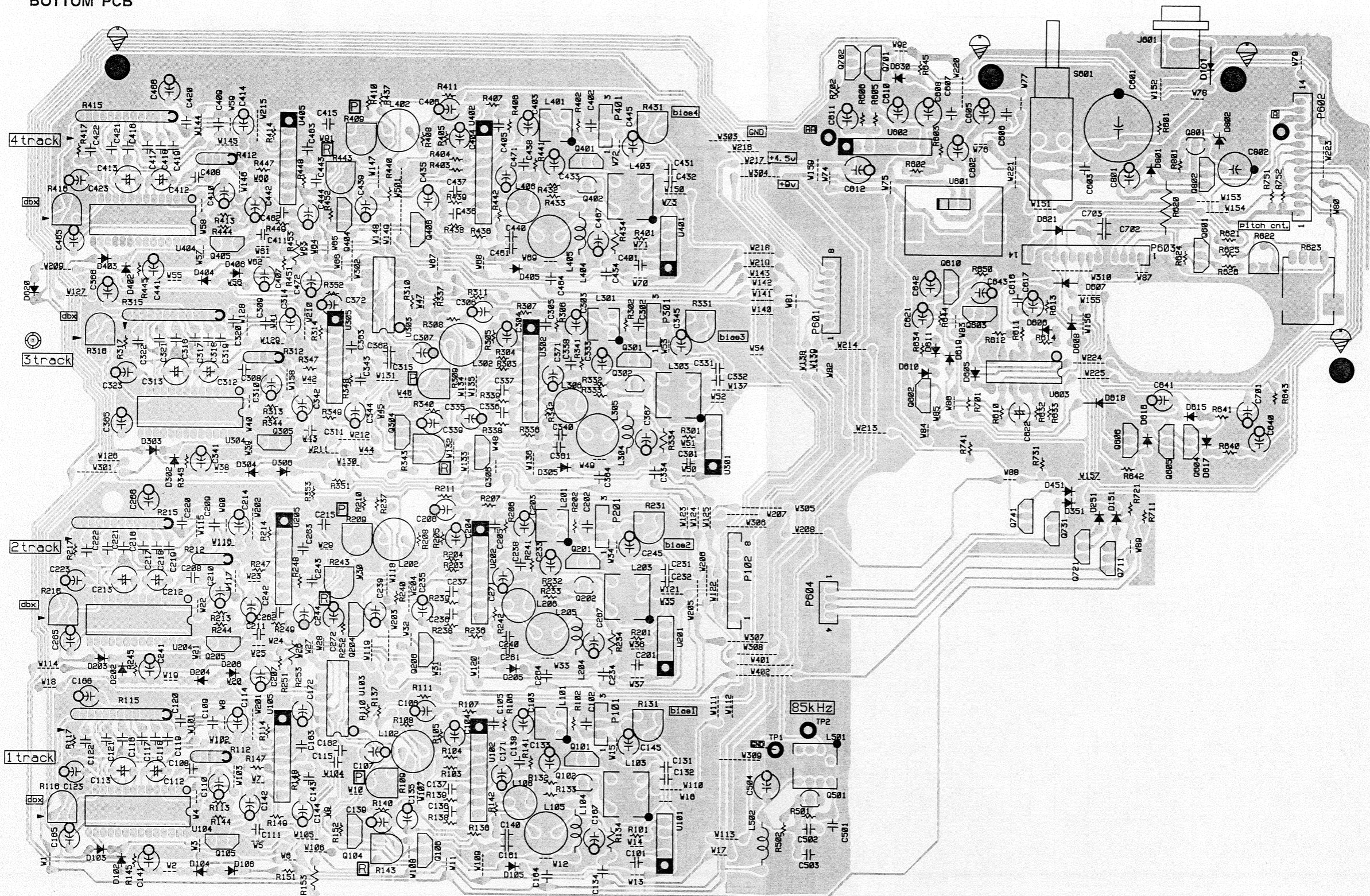

MIXER PCB ASSY

REF. NO.	PARTS NO.	DESCRIPTION
	*9145200100	MIXER PCB ASSY
	*9155200100	MIXER PCB
	*9107091600	14P MIXER WIRES
	*9107091700	8P MIXER WIRES
D60	9174021520	LED, L-9341T (RED)
D185-485	9174021520	LED, L-9341T (RED)
D186-486	9174021520	LED, L-9341T (RED)
D187-487	9174021520	LED, L-9341T (RED)
D188-488	9174021620	LED, L-934YC (YELLOW)
D189-489	9174021620	LED, L-934YC (YELLOW)
D190-490	9174021520	LED, L-9341T (RED)
D501	9174021520	LED, L-9341T (RED)
D601, 602	9165022150	D, TP 1SS133T
J101	9143917000	JACK, 064-3 (BLK)
J151-153	9143387000	JACK, 2P YKC21-3063 (BLK)
J154	9143919000	JACK, 064-0-2 (RED)
J155, 156	9143916000	JACK, 064-2 (BLK)
J157	9143916000	JACK, 064-2 (BLK)
J158	9144333000	JACK, RCA YKC-21-3048
J201-401	9143917000	JACK, 064-3 (BLK)
J501	9143491000	JACK, 064 (BLK)
J701	9143918000	JACK, 064-4 (BLK)
P101, 102	9144034001	CN, TUC-P5P-B1
P201	9144034001	CN, TUC-P5P-B1
P202	9144033001	CN, TUC-P4P-B1
P301	9144034001	CN, TUC-P5P-B1
P302	9144033001	CN, TUC-P4P-B1
P501	9144035001	CN, TUC-P6P-B1
P502	9144041001	CONNECTOR PLUG, 12P
Q50	9163011220	TR, DTA 124ES TP
Q51	9163310420	TR, DTC 124ES TP
Q151-154	9163450020	TR, DTC314TS
Q171, 271	9163450020	TR, DTC314TS
R50	△ 9114433060	R, NONFLMMABLE 1W 15
R105-405	9172031900	VR, RS20111P9009TK-10KRD
R107-407	9172032600	VR, RS45111 P6022 10KA TK
R111-411	9172030500	VR, EVUF3AF30B15100KB
R114-414	9172030500	VR, EVUF3AF30B15100KB
R118-418	9172030400	VR, EVUF1AF30B14 10KB
R121-421	9172030300	VR, EVU FOA F30 A14 10KA
R123-423	9172030300	VR, EVU FOA F30 A14 10KA
R152	9172032700	VR, RS60112 P6026 10KAX2
R172	9172030700	VR, EVJY00F30A14 10KAX2
R501	9172030700	VR, EVJY00F30A14 10KAX2
R701	9172030700	VR, EVJY00F30A14 10KAX2
S101	9135037000	SLIDE SW, SSSH013NB2
S102	9135036300	SLIDE SW, SSSU042NA2-TK
S152-154	9135037300	SW, PS009-PA022BAT-PA 5. 5
S161	9135035200	SLIDE SW, SSSU023NB2-TK
S162	9135037000	SLIDE SW, SSSH013NB2

MIXER PCB ASSY

REF. NO.	PARTS NO.	DESCRIPTION
S163	9135037400	SLIDE SW, SSSU022-S09N1
S201	9135037000	SLIDE SW, SSSH013NB2
S261	9135035200	SLIDE SW, SSSU023NB2-TK
S301	9135037000	SLIDE SW, SSSH013NB2
S361	9135035200	SLIDE SW, SSSU023NB2-TK
S401	9135037000	SLIDE SW, SSSH013NB2
S461	9135035200	SLIDE SW, SSSU023NB2-TK
U101, 301	9167015910	IC, NJM2068SD
U102-402	9167015800	IC, NJM4565L
U151, 251	9167015800	IC, NJM4565L
U152	9167015800	IC, NJM4565L
U153	9167022300	IC, LA6515
U185-485	9167017000	IC, LB1423N

BOTTOM PCB ASSY

REF. NO.	PARTS NO.	DESCRIPTION
	*9145201103	BOTTOM PCB ASSY
	*9155201100	BOTTOM PCB
	*9783603008	SCREW, BTT-P M3X8
C601	△ 9117303600	C, ELEC 4700UF 25V
D101	9165024350	D, RB-100A
D102-402	9165022150	D, TP 1SS133T
D103-403	9165022150	D, TP 1SS133T
D104-404	9165022150	D, TP 1SS133T
D105-405	9165022150	D, TP 1SS133T
D106-406	9165022150	D, TP 1SS133T
D151-451	9165022150	D, TP 1SS133T
D605-608	9165022150	D, TP 1SS133T
D610, 611	9165022150	D, TP 1SS133T
D615-621	9165022150	D, TP 1SS133T
D630	9165022150	D, TP 1SS133T
D801	9165022150	D, TP 1SS133T
D802	9166054251	D, ZENER MTZ J 11B
J601	9144357000	JACK, DC POWER DJ-0702N
L101-401	9173009300	COIL, TRAP 85KHZ
L102-402	9173009400	COIL, L. P. F. 85KHZ
L103-403	9173010800	COIL, SLAVE
L104-404	9173010600	COIL, 10UHJ
L105-405	9173009400	COIL, L. P. F. 85KHZ
L106-406	9173008700	COIL, 36MH
L501	9173010700	COIL, MASTER OSC
L502	9173006350	COIL, 220MH EC35-221K
P101	9143171000	PLUG, CONNECTOR B3B-EH 3P
P102	9143176000	PLUG, 8P B8B-EH-K
P201	9143171020	PLUG, CONNECTOR B3B-EH-A B
P301	9143171010	PLUG, CONNECTOR B3B-EH-A R

BOTTOM PCB ASSY

REF. NO.	PARTS NO.	DESCRIPTION
P401	9143171040	PLUG, CONNECTOR 3P
P601	9143236000	PLUG, 8P B8B-PH
P602	9143242000	PLUG, 14P B14B-PH-K
P603	9143242020	PLUG, 14P B14B-PN-K
P604	9143232000	PLUG, B4B-PH 4P
Q101-401	9163014220	TR, DTC363ES TP
Q102-402	9163450300	TR, 2SC2002L
Q104-404	9163450020	TR, DTC314TS
Q105-405	9163450020	TR, DTC314TS
Q106-406	9163011220	TR, DTA 124ES TP
Q501	9163450520	TR, 2SC2603-T11-F
Q601	9164004620	FET, 2SK381-T11-D
Q602	9163011220	TR, DTA 124ES TP
Q603	9163310420	TR, DTC 124ES TP
Q604	9163011220	TR, DTA 124ES TP
Q605	9163310420	TR, DTC 124ES TP
Q606	9163015520	TR DTD 123TS
Q610	9163310420	TR, DTC 124ES TP
Q701	9163310420	TR, DTC 124ES TP
Q702	9163011220	TR, DTA 124ES TP
Q711-741	9163202620	TR, DTB143ES TP
Q801	9163309420	TR, 2SC1815GR (TP)
Q802	9163011220	TR, DTA 124ES TP
R109-409	9112059810	VR, 10K TB067A
R112-412	9111255000	R, ARRAY EXBZ5L045G DBX
R115-415	9111256000	R, ARRAY EXBZ13L046G DBX
R116-416	9112056010	VR, 4. 7K TB067A
R131-431	9112059510	VR, 200K TB067A
R143-443	9112059810	VR, 10K TB067A
R620	△ 9114725005	R, NONFLAMMABLE 2W 10
R622	9112058010	VR, 1K TB067A
R623	9172024100	VR, RK11K113A229-1. 5KB TK
S601	△ 9135032101	PUSH SW, SPUN19C606-TK
U101-401	9167017200	IC, BA7755
U102-402	9167015910	IC, NJM2068SD
U103, 303	9167009800	IC, TC4066BP
U104-404	9167026100	IC, AN7367K
U105-405	9167015800	IC, NJM4565L
U601	9167025600	IC, NJM317F
U601	9260259000	HEAT SINK, CS-B2202-02317
U602	9167015010	IC, M5218L
U603	9167026900	IC, TC4069UBP

JUMP A PCB ASSY

REF. NO.	PARTS NO.	DESCRIPTION
	*9145200200	JUMP A PCB ASSY
	*9155200200	JUMP A PCB
	*9107091800	4P JUMP WIRES
J1-J3	9144132001	CONNECTOR, TUC-P5X-B1
J4	9144133001	CONNECTOR, TUC-P6X-B1

JUMP B PCB ASSY

REF. NO.	PARTS NO.	DESCRIPTION
	*9145200300	JUMP B PCB ASSY
	*9155200300	JUMP B PCB
J11	9144132001	CONNECTOR, TUC-P5X-B1
J21	9144131001	CONNECTOR, TUC-P4X-B1
J31	9144131001	CONNECTOR, TUC-P4X-B1
J51	9144139001	CONNECTOR PLUG, 12P

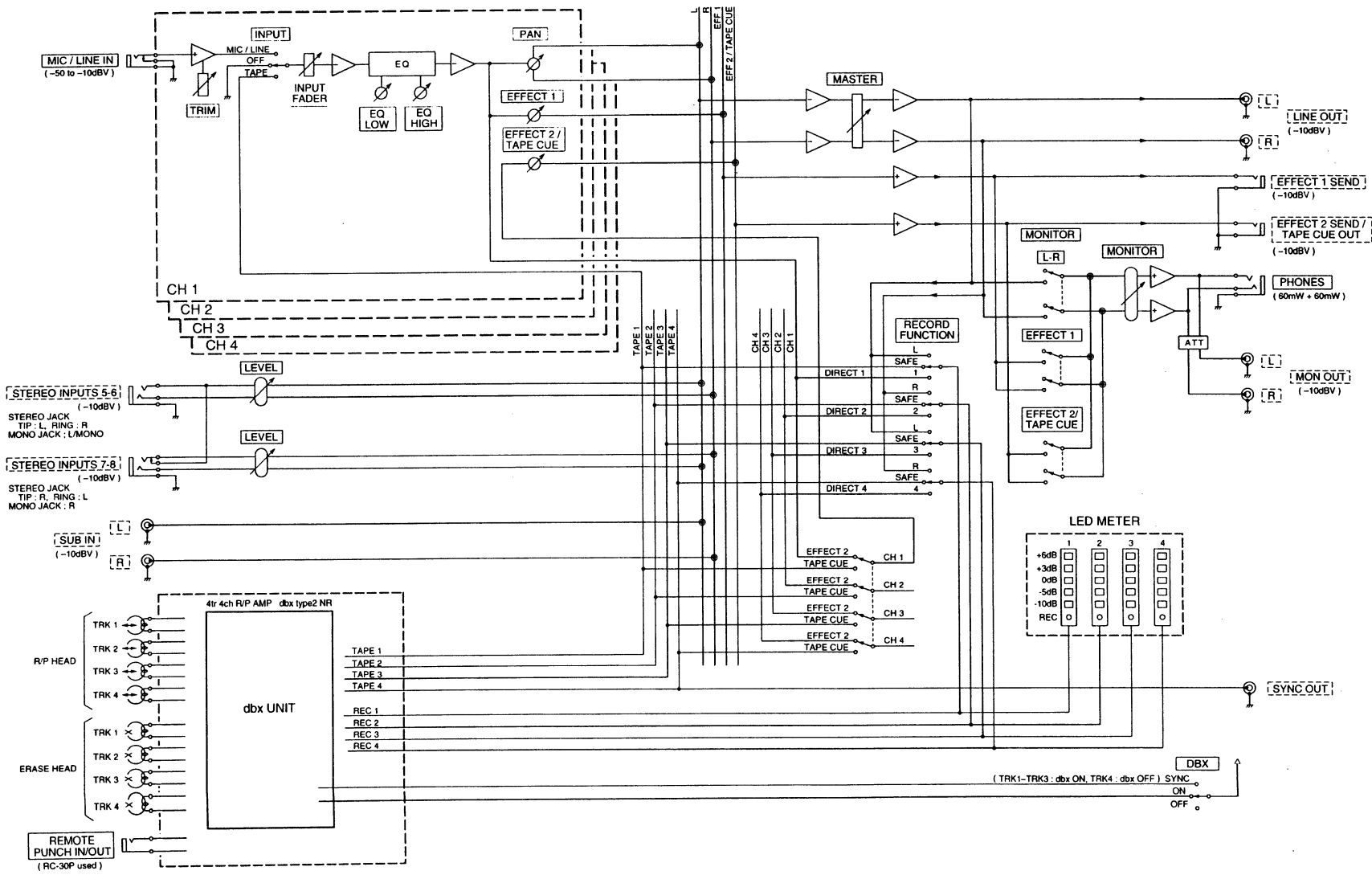

6. BLOCK DIAGRAM
 ロック・タイタラム

7. LEVEL DIAGRAM

レベル・ダイアグラム

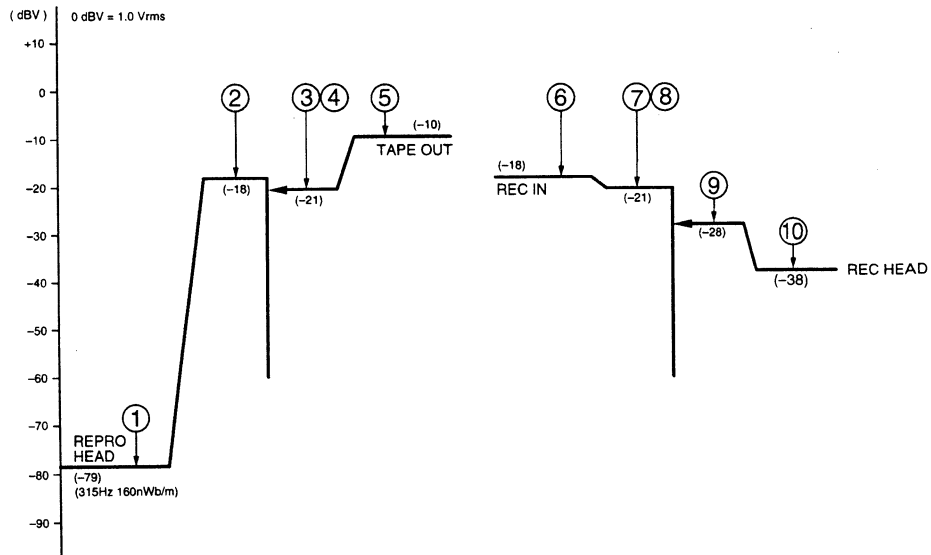
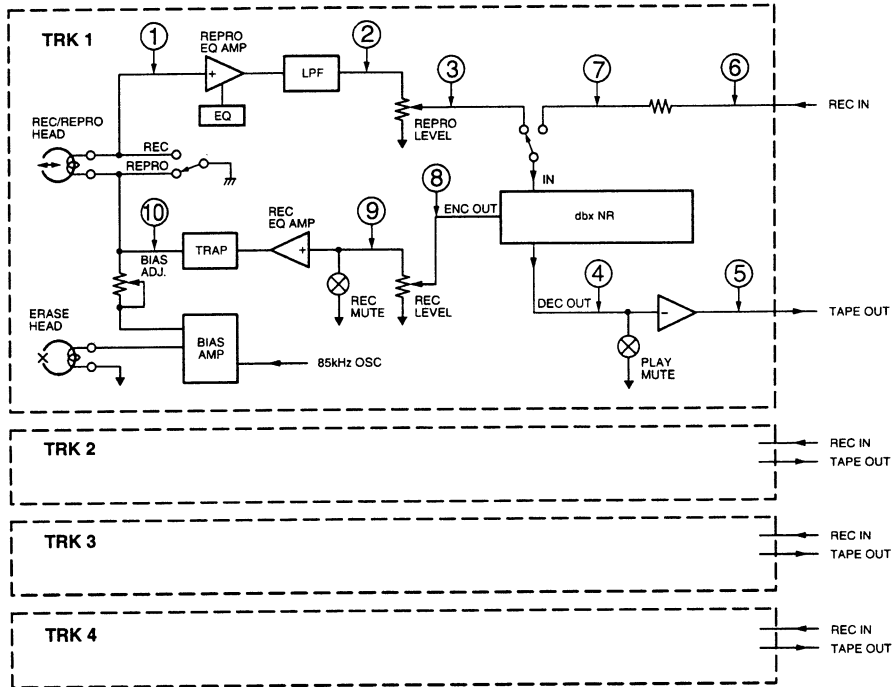

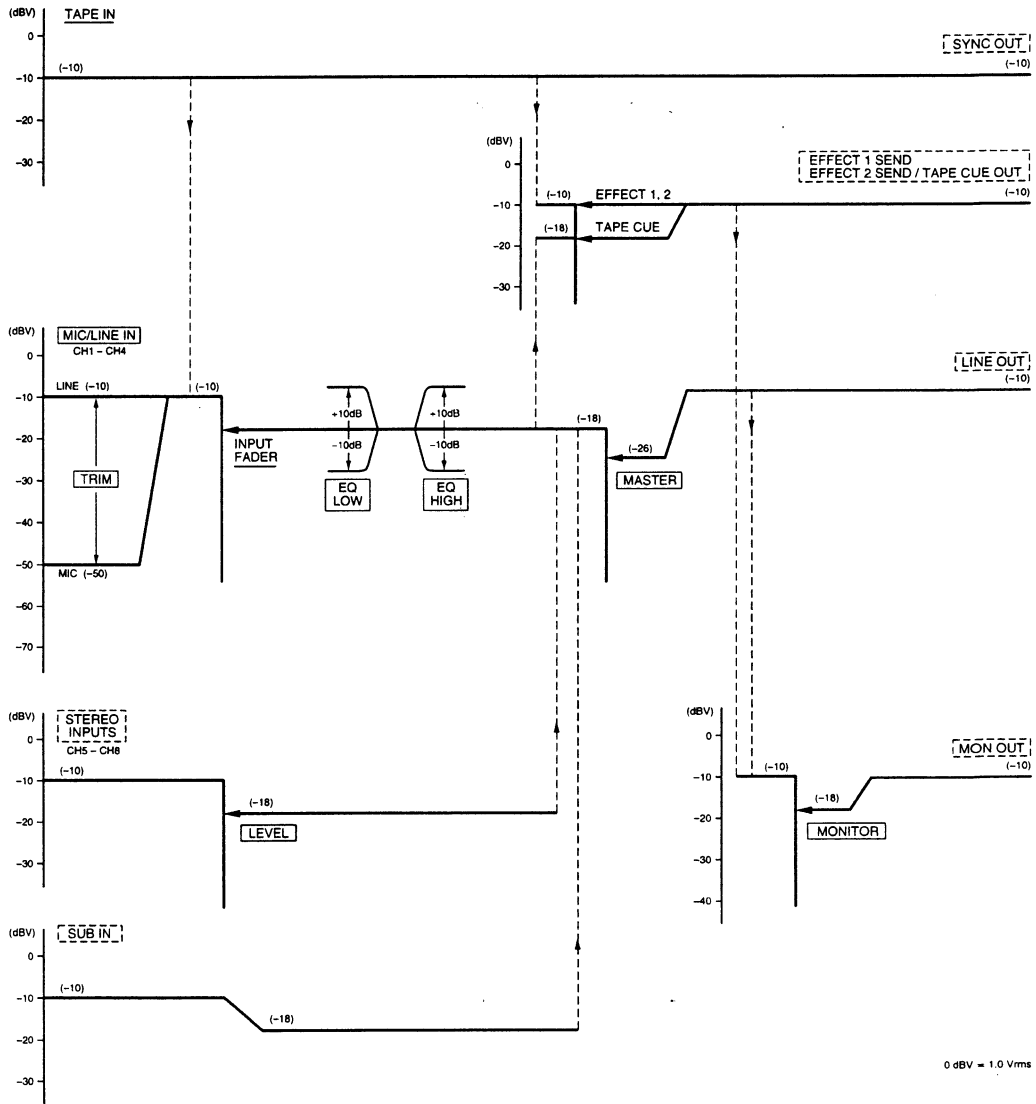

1 2 3 4 5

A
B
C
D
E
F
G
H

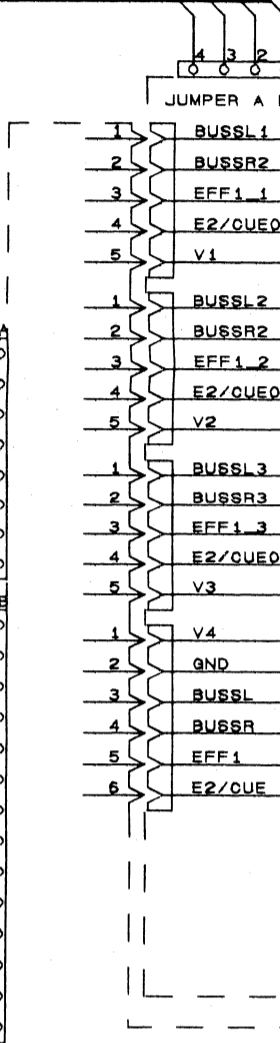
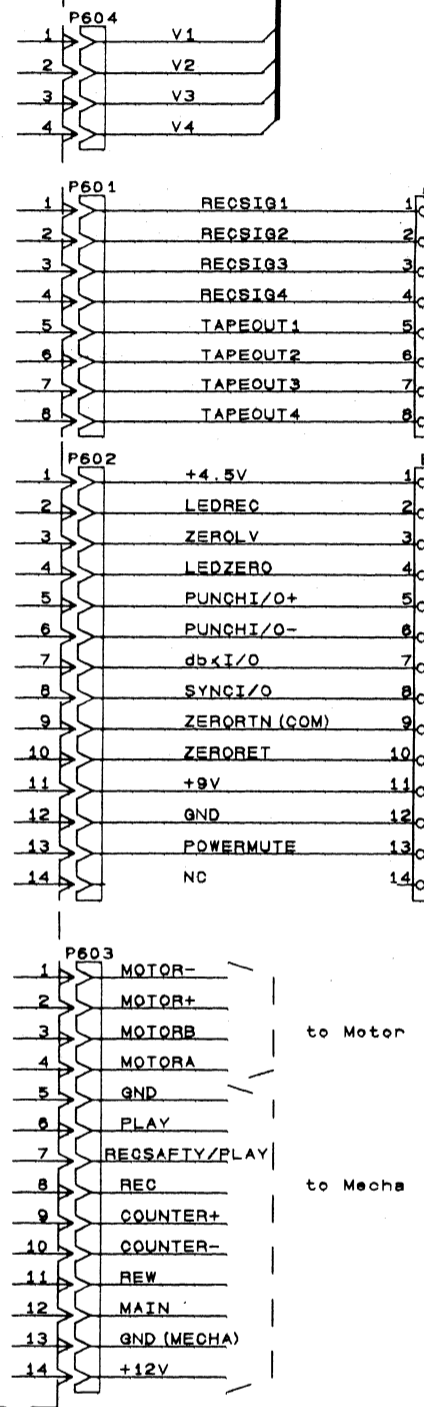
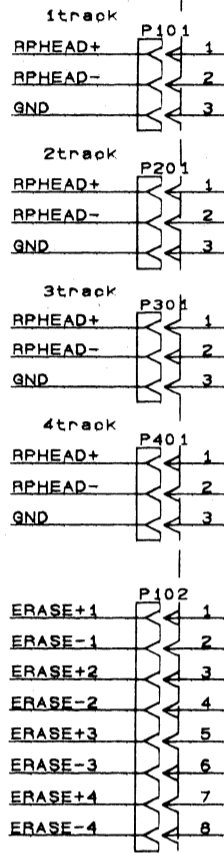

BOTTOM PCBASSY

to Motor
to Mecha

MIXE

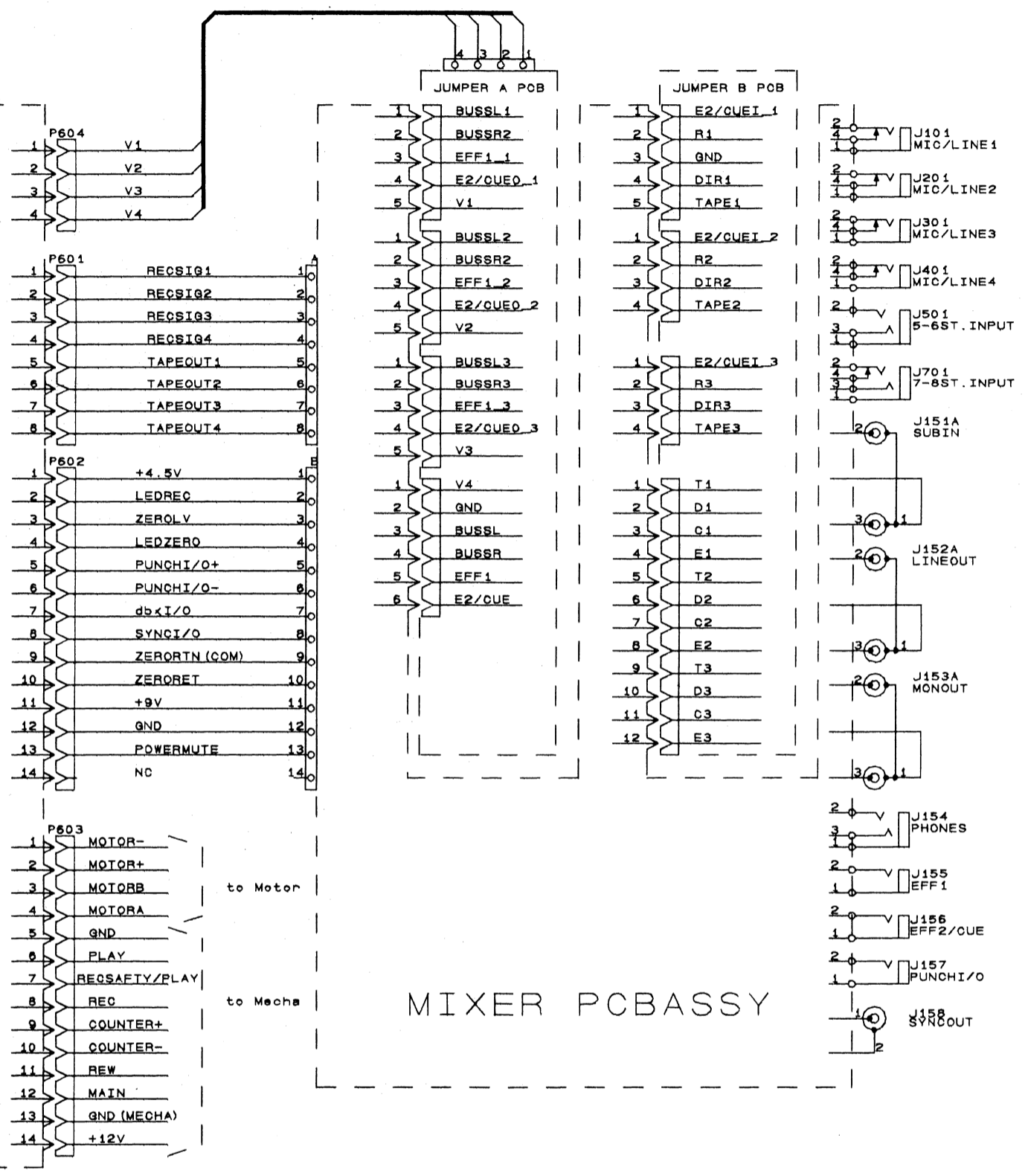

MIXER PCBASSY

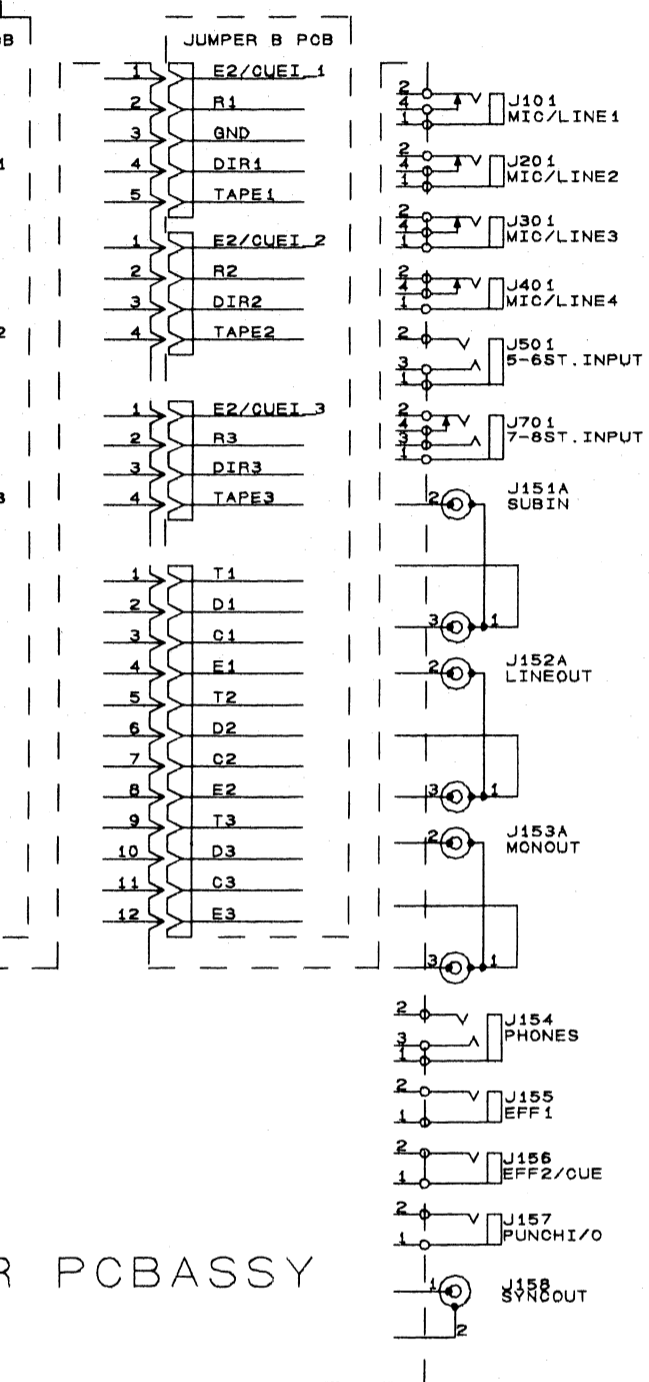

1 2 3 4 5 6

A
B
C
D
E
F
G
H

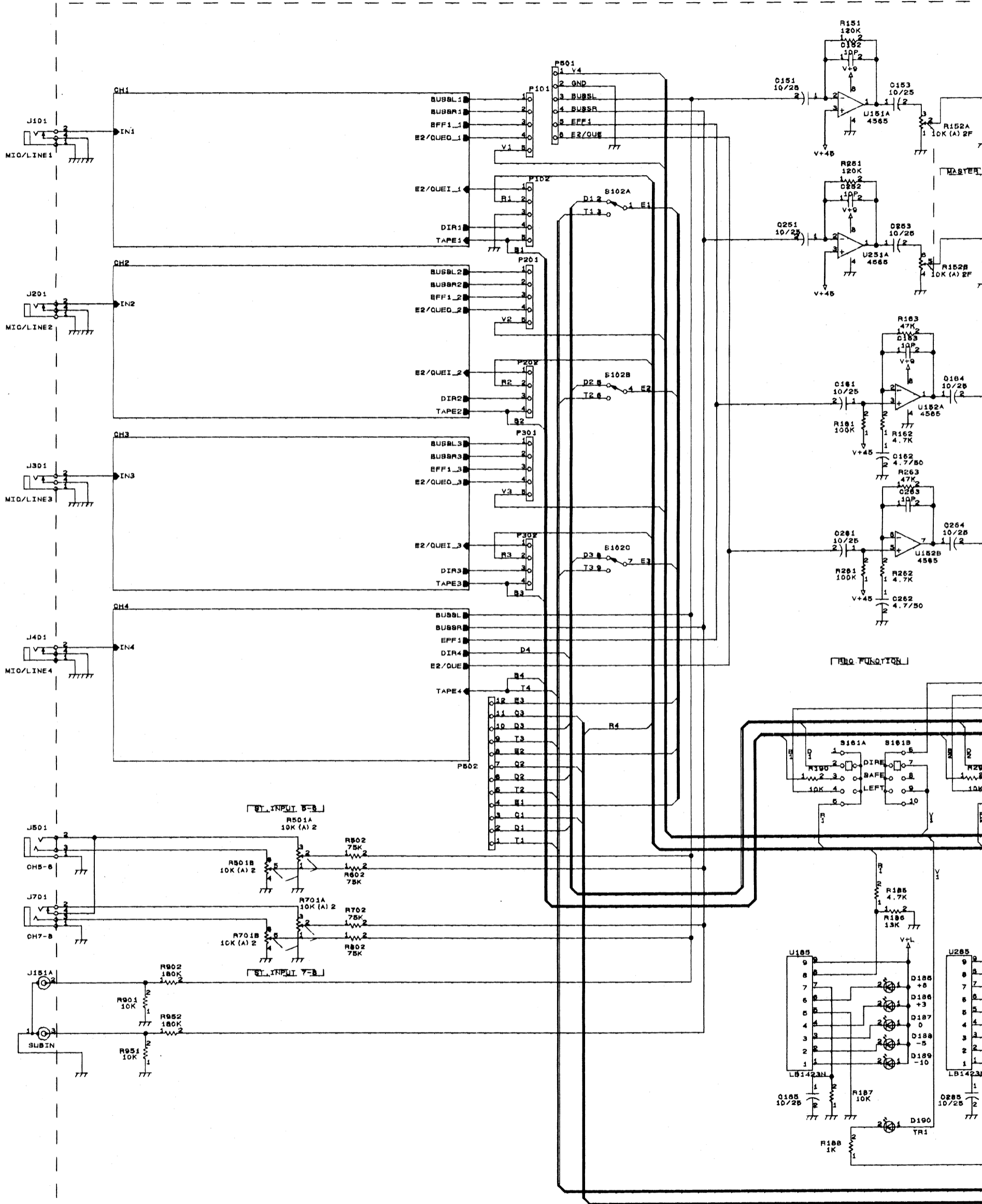

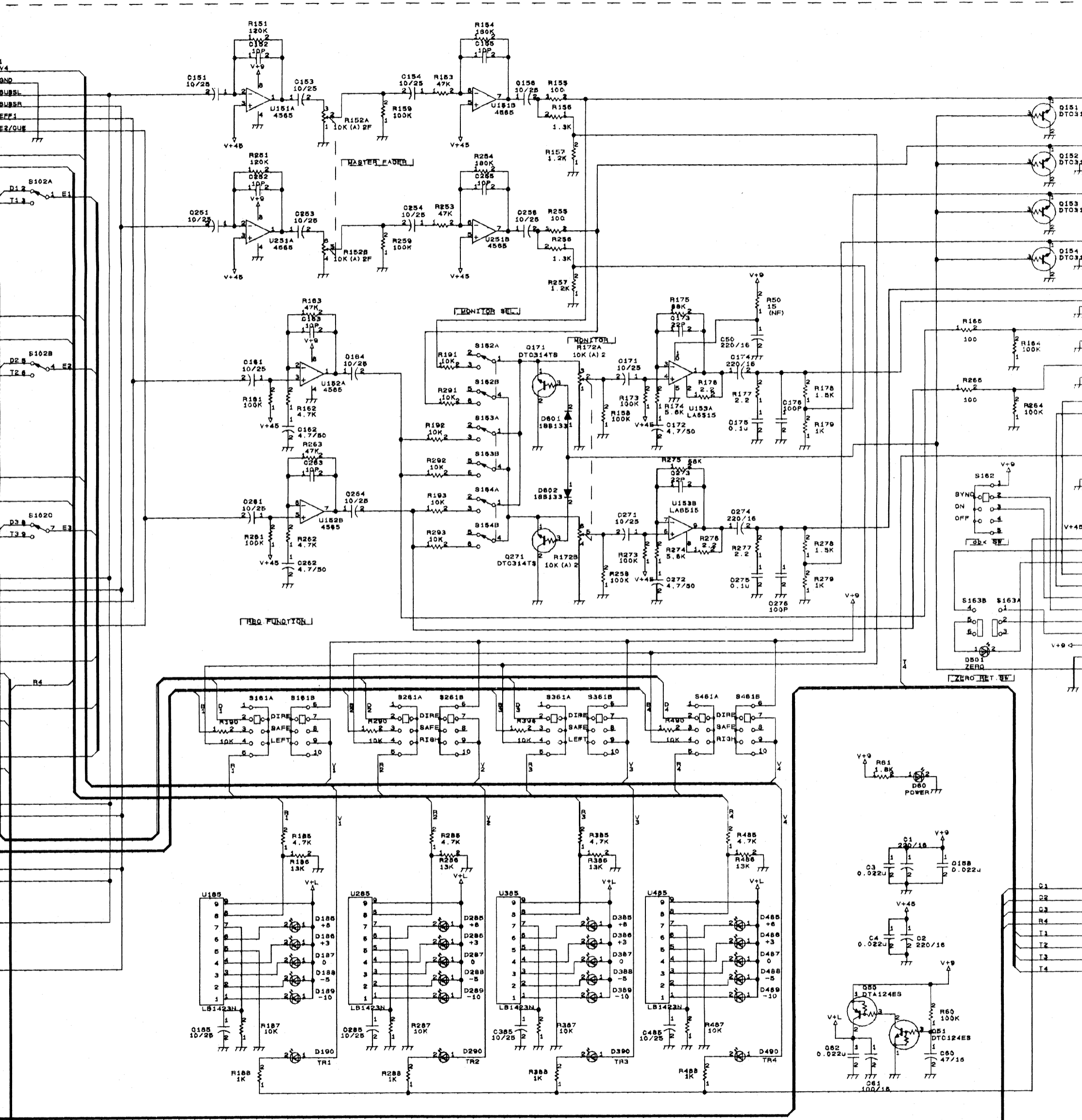

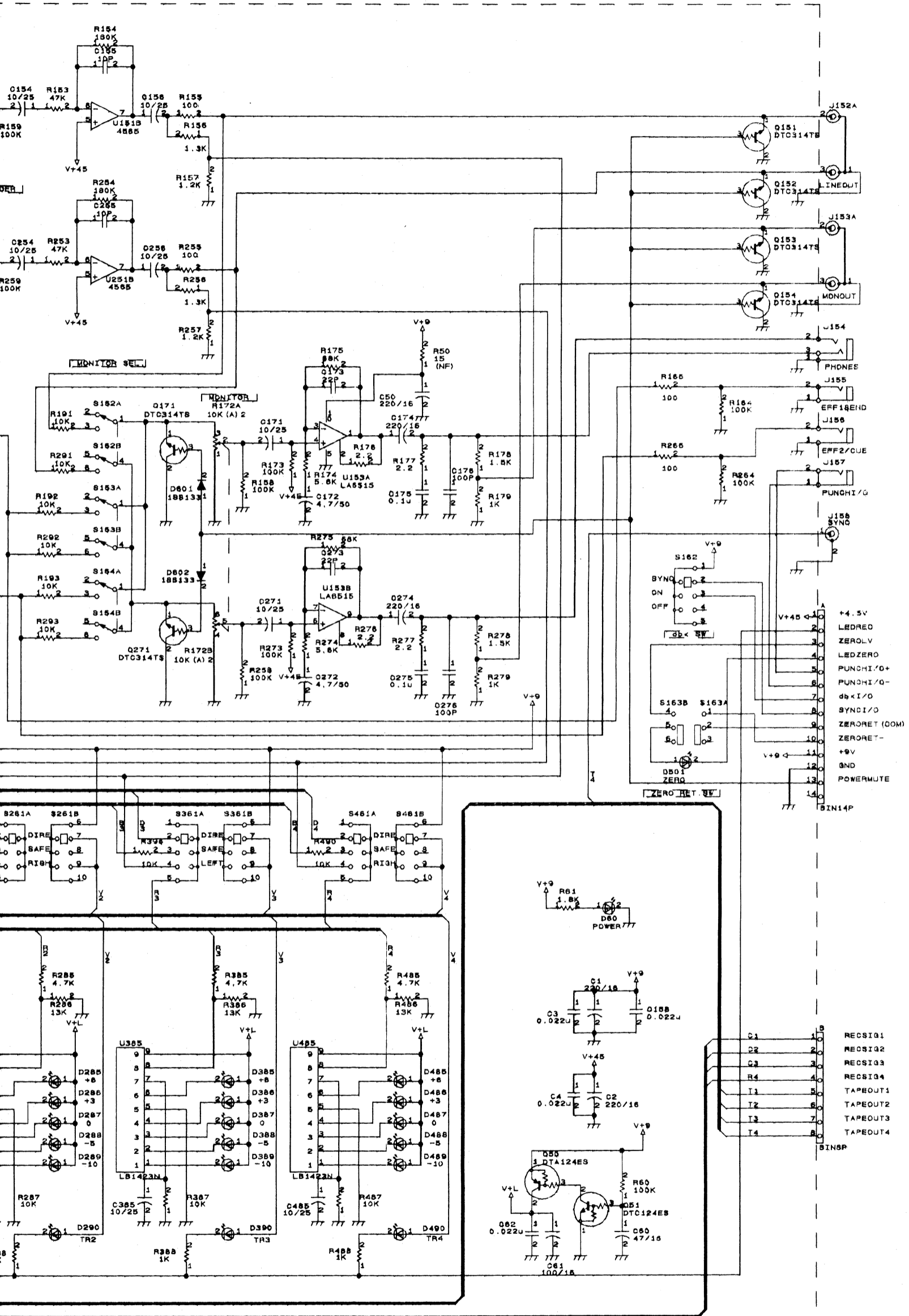

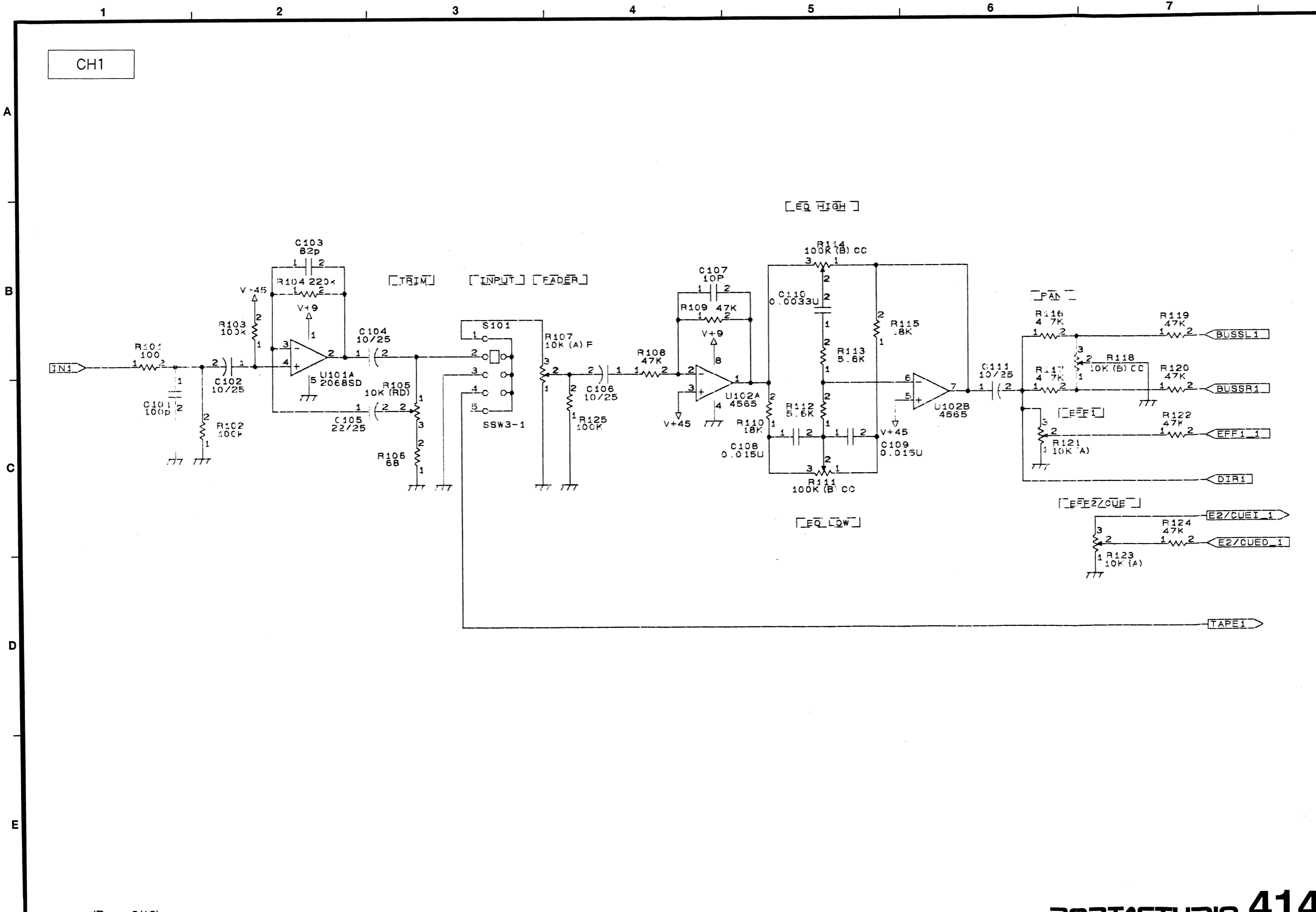

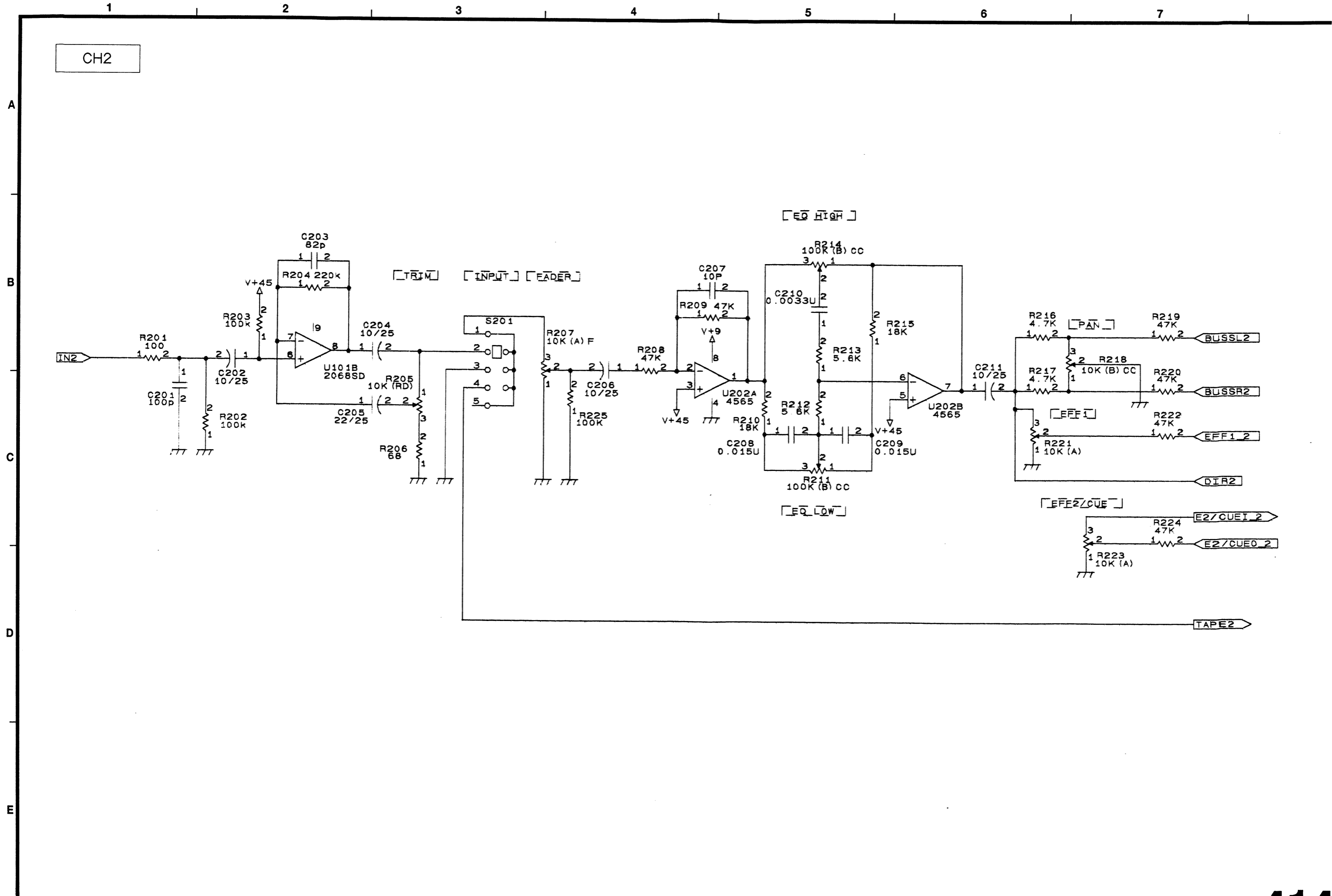

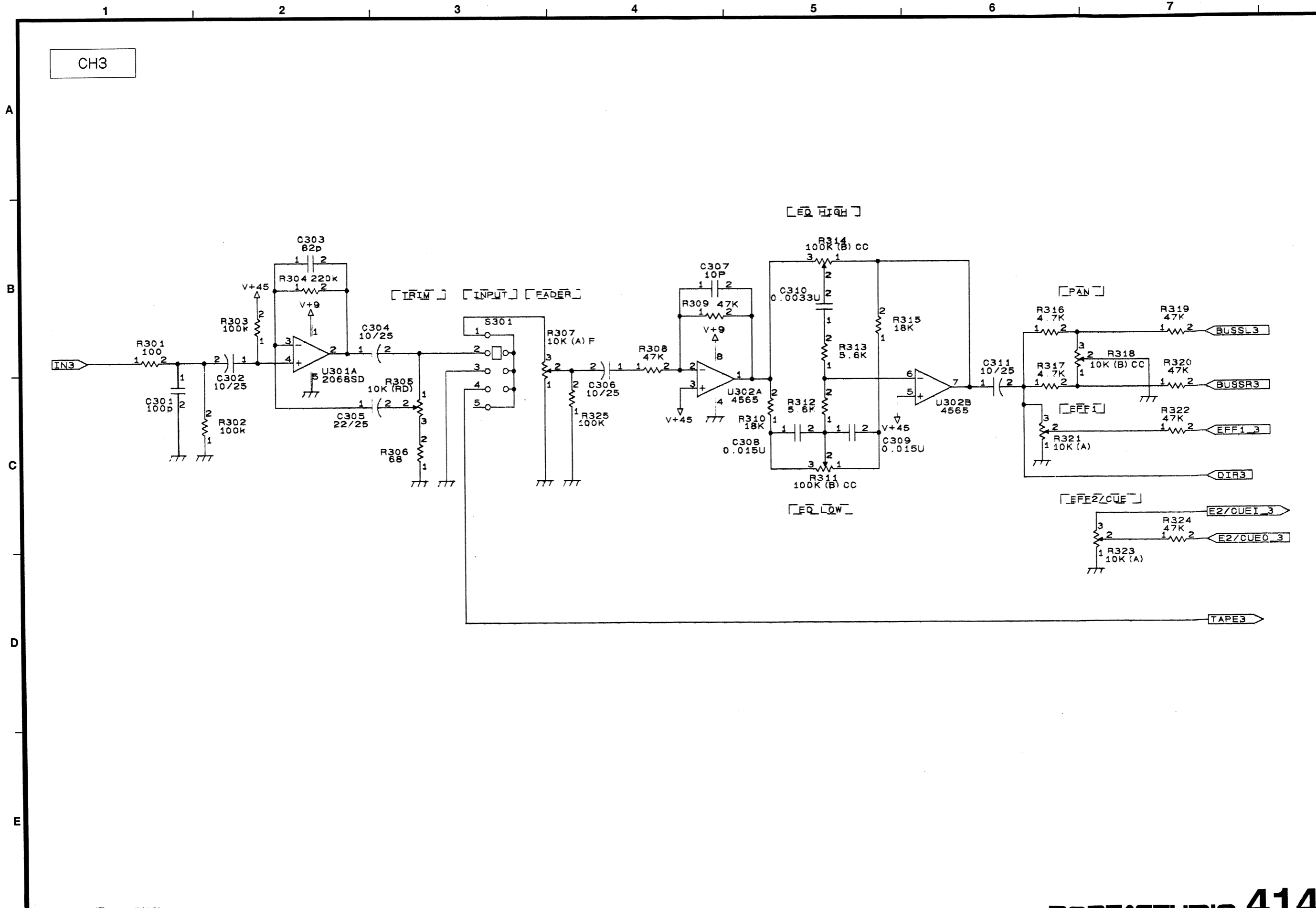

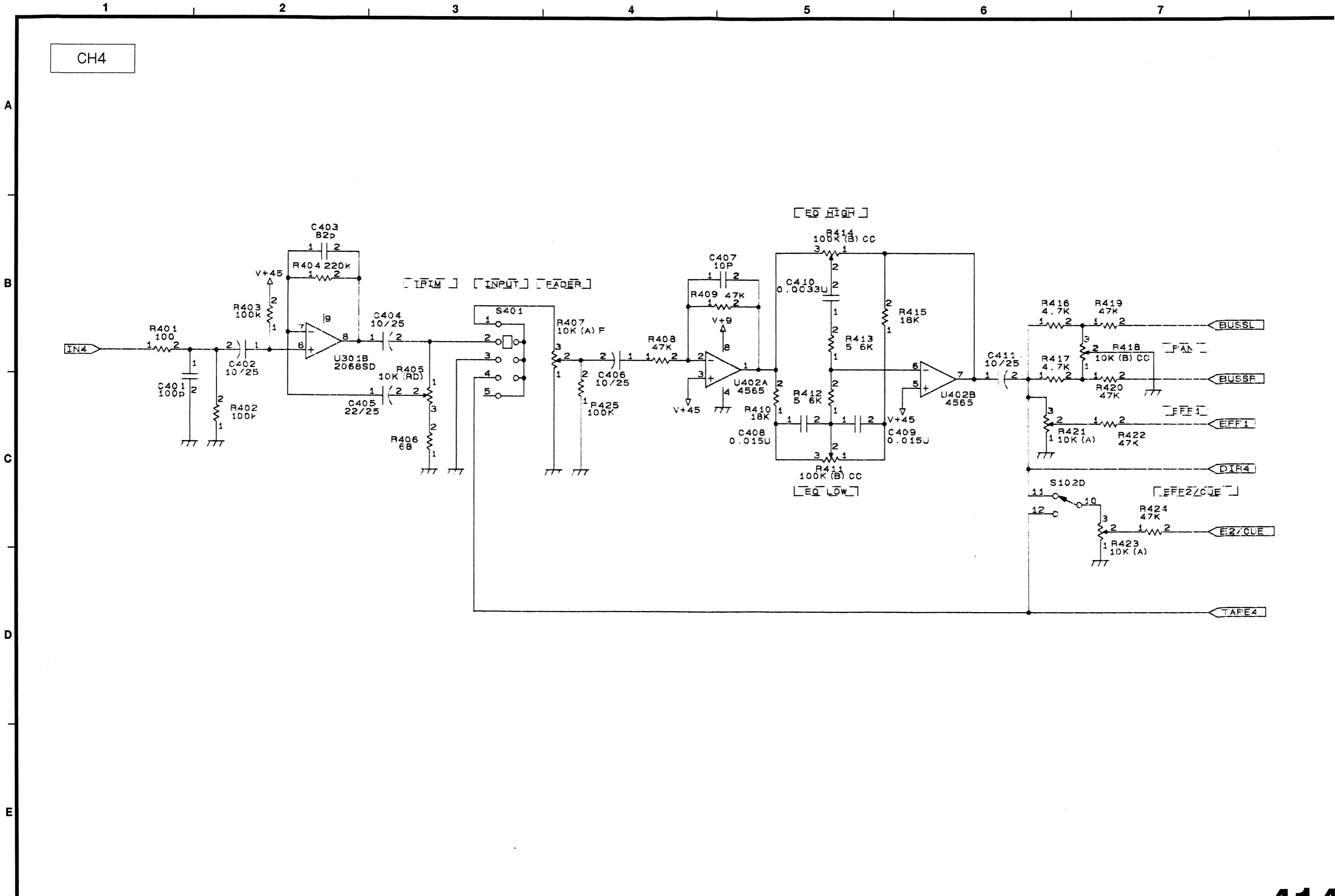

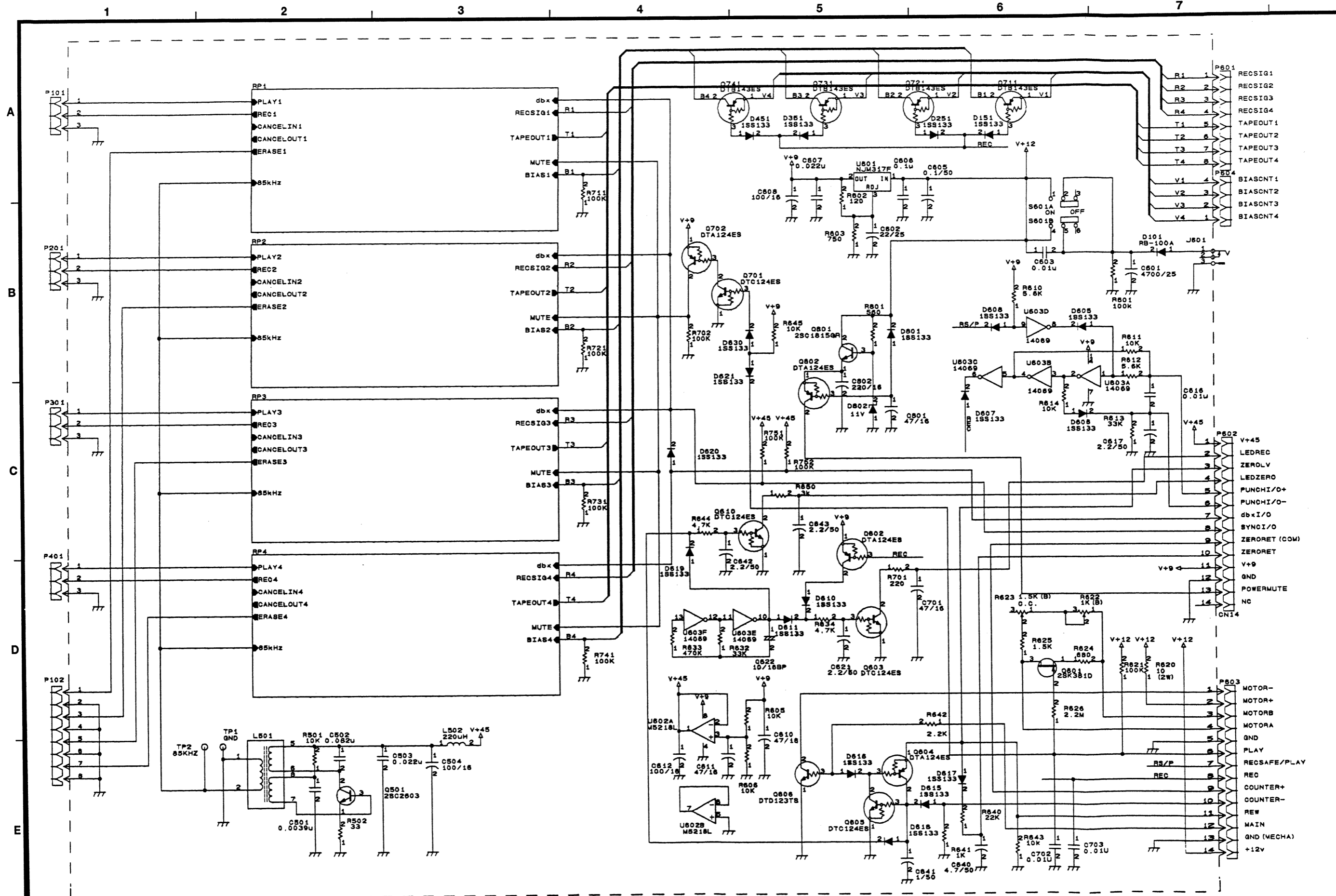

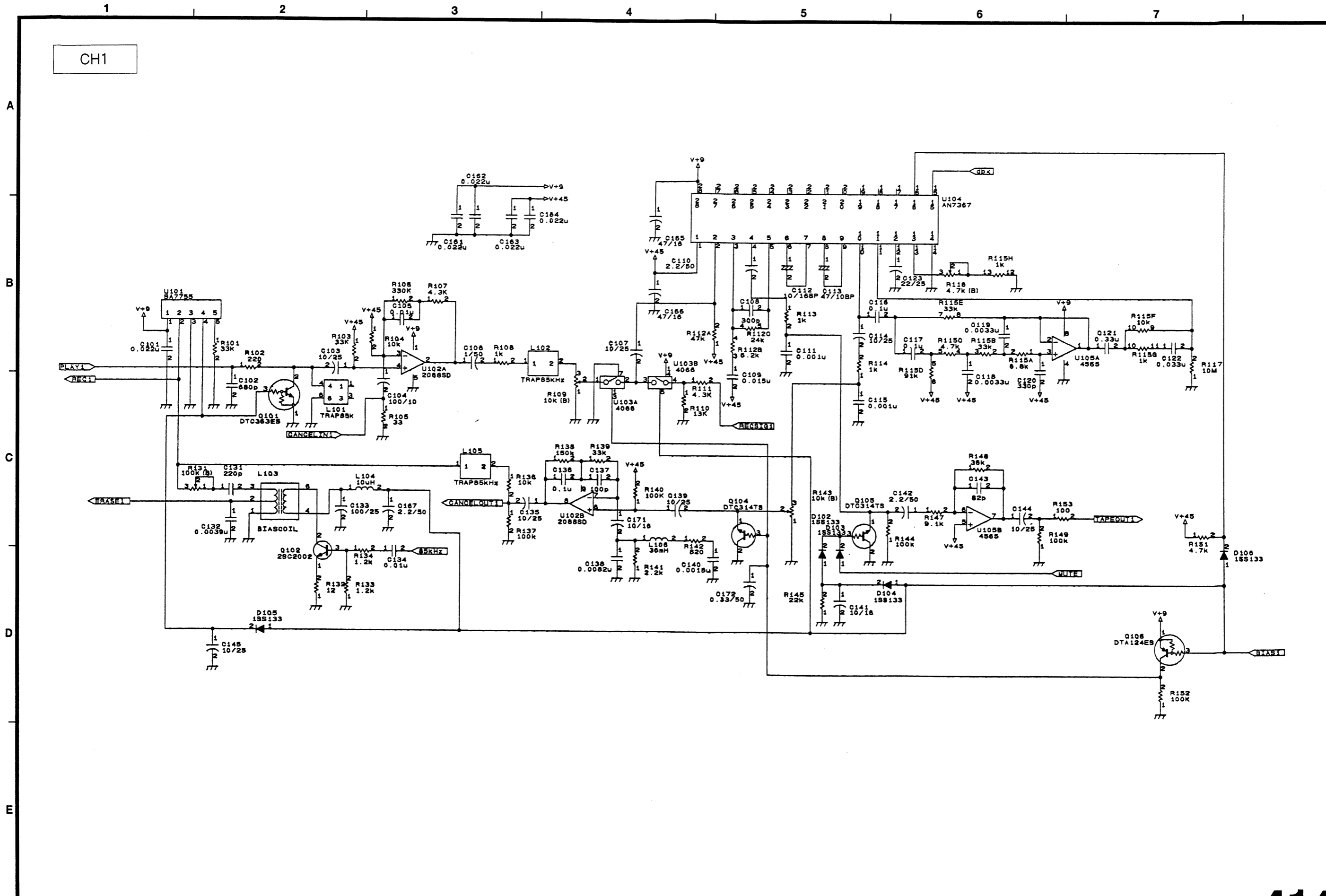

1 2 3 4 5 6 7

CH2

A
B
C
D
E

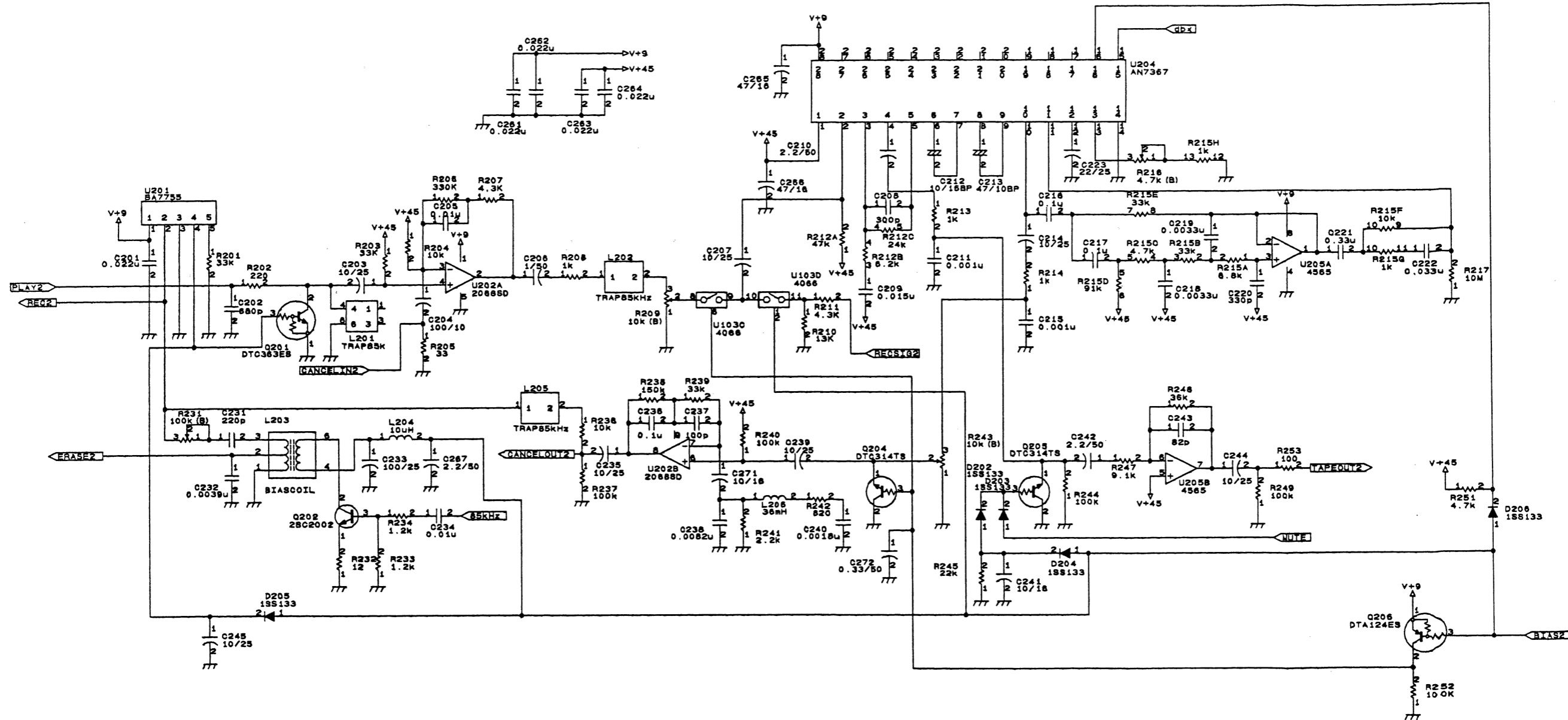

1

2

3

4

5

6

7

CH3

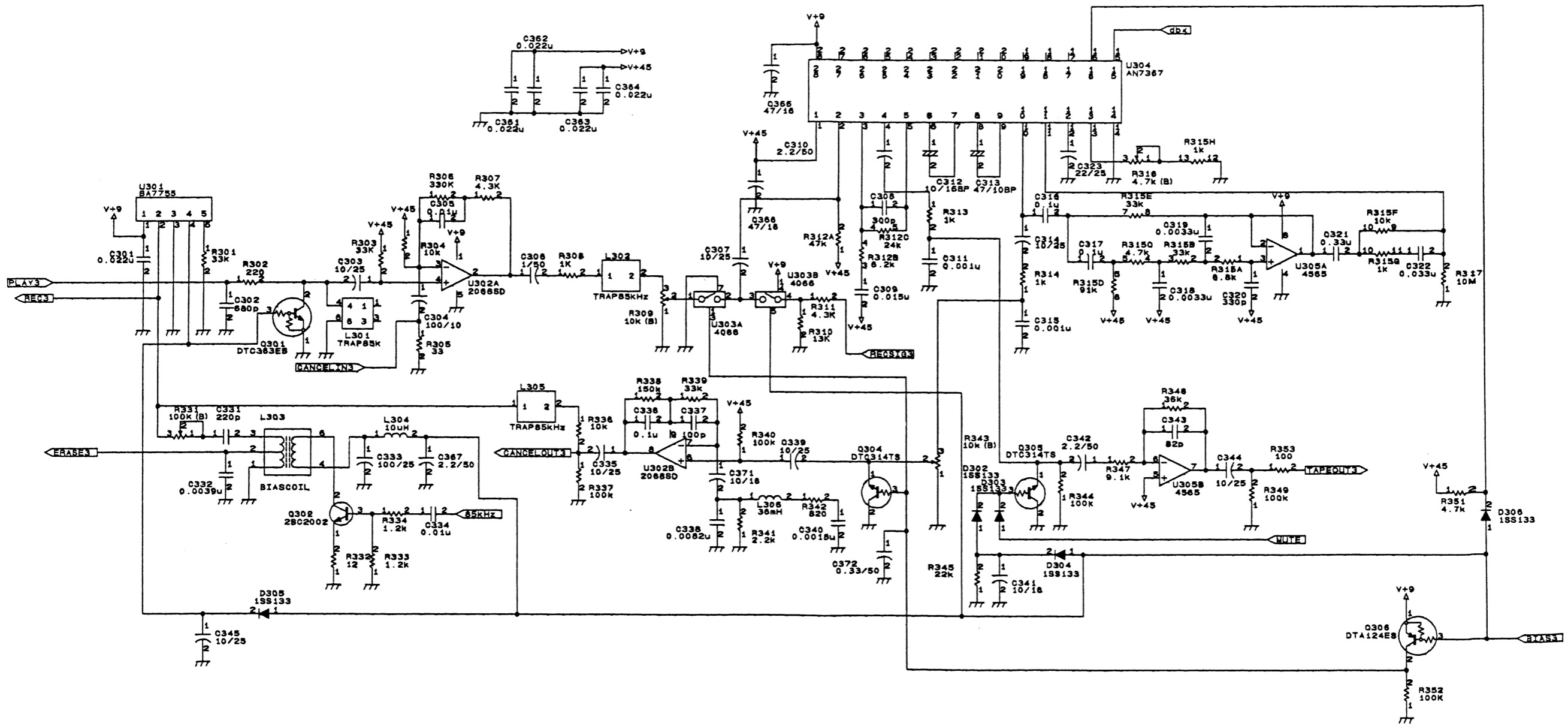

1 2 3 4 5 6 7

CH4

A
B
C
D
E

